

**TECHNICAL SPECIFICATION - BTM<sup>®</sup> TS31**

**LOW CARBON ERW STEEL TUBING WITH SPECIAL REQUIREMENTS**

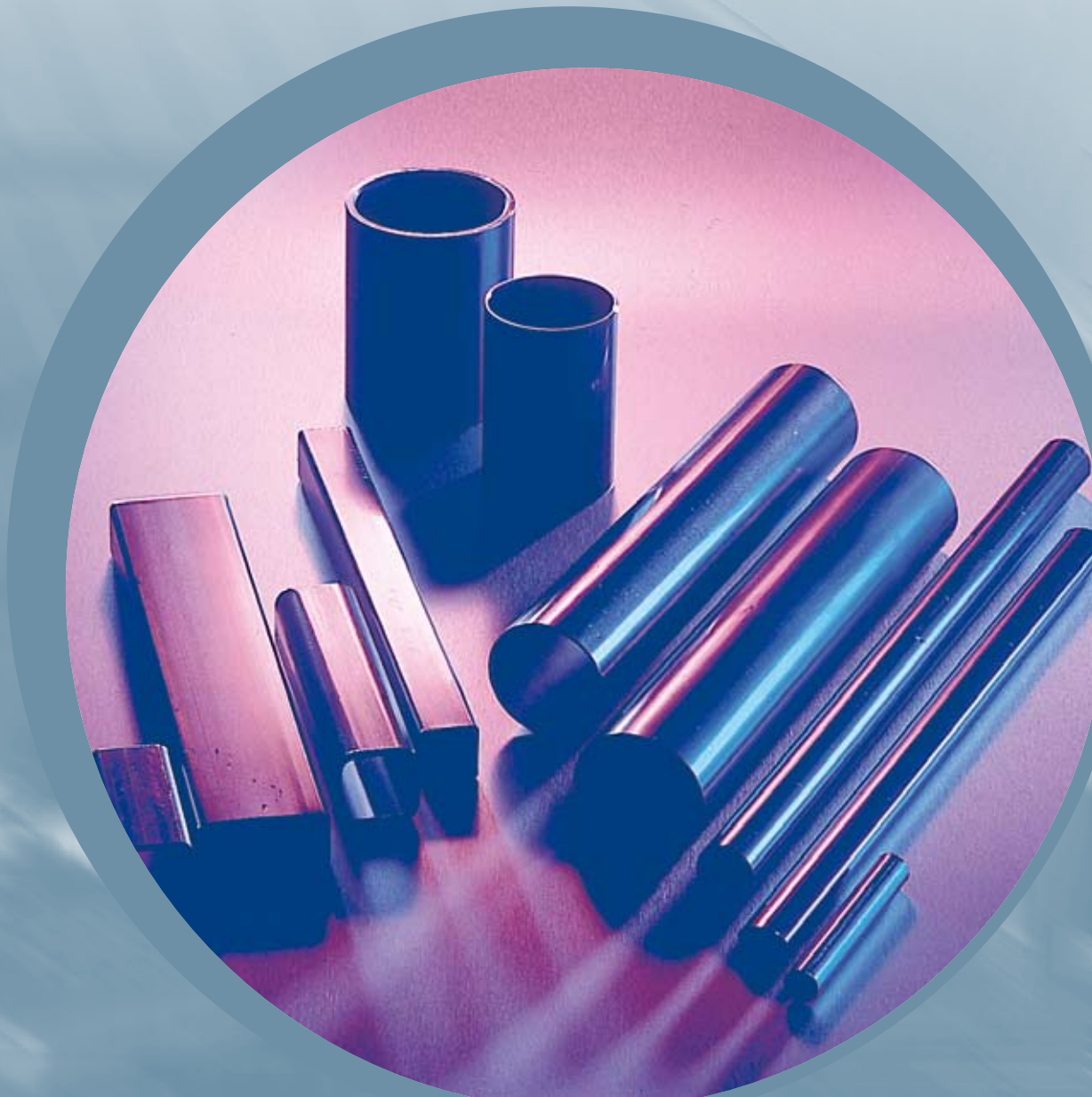

**TABLE OF CONTENTS**

		<b>PAGE</b>
<b>1.0</b>	Scope	<b>1</b>
<b>2.0</b>	References	<b>1</b>
<b>3.0</b>	Definitions	<b>1</b>
<b>4.0</b>	Designation	<b>1</b>
<b>5.0</b>	Information to be Supplied by the Purchaser	<b>2</b>
<b>6.0</b>	Requirements	<b>2</b>
<b>6.1</b>	Tube Condition	<b>2</b>
<b>6.2</b>	Chemical Composition	<b>2</b>
<b>6.3</b>	Mechanical Properties	<b>3</b>
<b>6.4</b>	Test Certificates	<b>4</b>
<b>6.5</b>	Surface Finish	<b>5</b>
<b>6.6</b>	Tube Dimension and Wall Thickness	<b>6</b>
<b>6.7</b>	Length	<b>8</b>
<b>6.8</b>	Height of Weld Upset	<b>10</b>
<b>6.9</b>	End Condition	<b>11</b>
<b>6.10</b>	End Welds (Cross Welds)	<b>12</b>
<b>6.11</b>	Straightness	<b>12</b>
<b>6.12</b>	Non-Circular Tube - Other Features	<b>13</b>
<b>6.13</b>	Rust Prevention	<b>14</b>
<b>6.14</b>	Packaging	<b>15</b>
<b>6.15</b>	Special Requirements	<b>15</b>
<b>7.0</b>	Control	<b>15</b>

## 1.0 | Scope

This specification covers the technical requirements for the production and supply of low carbon ERW (electric resistance welded) steel tubing supplied in the As Formed condition with special requirements in relation to internal fin cutting, dimensional tolerances, mechanical tests and/or other additional requirements. This product is intended for use in furniture and other general applications requiring ductile tubing.

- Note:
1. Tubing in the As Formed condition with a Black surface finish and produced from Black (hot rolled) strip for general applications, is covered in;  
TS11 Black (Hot Rolled) ERW Steel Tubing.
  2. Tubing in the As Formed condition with a Commercial Quality or Bright Quality surface finish without any special requirements (BTM<sup>®</sup> EzyForm<sup>™</sup>), is covered in;  
TS21 Low Carbon ERW Steel Tubing for General Applications.
  3. Tubing in other steel grades, which is supplied with specified tensile properties or specific chemistries for structural and mechanical purposes, is covered in;  
TS22 ERW Steel Tubing with Specified Mechanical Properties (Hi-Lite<sup>®</sup>).
  4. Tubing supplied in the As Formed condition intended for use in fluid carrying applications which require an eddy current test, is covered in;  
TS41 Low Carbon ERW Steel Tubing for Fluid Carrying Applications.

## 2.0 | References

BTM<sup>®</sup> Customer Information Handbook – Standard Terminology

## 3.0 | Definitions

Terms used in this specification are defined in the BTM<sup>®</sup> Customer Information Handbook Standard Terminology.

## 4.0 | Designation

Tubing ordered to this specification shall be designated as TS31.

## 5.0 | Information to be Supplied by the Purchaser:

The purchaser should supply the following information at the time of an enquiry and/or order.

- (a) Dimensions of cross section (diameter/ non circular size and wall thickness).
- (b) Length required (in mm) and type (ML, NSML, CL) - refer to clause 6.7.
- (c) Designation eg TS31.
- (d) Surface finish ie Commercial Quality, Bright Quality or Black - refer to clause 6.5.1.
- (e) Quantity and delivery instructions
- (f) Any special requirements in relation to:
  - (1) Additional mechanical tests - refer to clause 6.3.4
  - (2) Surface finish - refer to clause 6.5.2
  - (3) Dimensional tolerances - refer to clause 6.6.4.
  - (4) Fin cutting - refer to clause 6.8.2.
  - (5) End distortion for tubing ordered as mill lengths or non-standard mill lengths - refer to clause 6.9.1.
  - (6) End conditions for tubing ordered as exact cut lengths - refer to clause 6.9.2.
  - (7) Straightness - refer to clause 6.11.
  - (8) Other features on non-circular tube - refer to clause 6.12.
  - (9) Any other features - refer to clause 6.15.
- (g) If test certificates are required - refer to clause 6.4.

## 6.0 | Requirements

### 6.1 Tube Condition

Tubing shall be supplied in the As Formed condition ie as produced ex the weldmill.

### 6.2 Chemical Composition

The cast analysis of the steel used shall conform to the following:

TABLE 1 : TS31 STANDARD CHEMISTRY		
	Guaranteed Maximum (%)	Typical (%)
Carbon (C)	0.10	0.060
Phosphorous (P)	0.040	0.015
Manganese (Mn)	0.45	0.20
Silicon (Si)	—	0.0050
Sulphur (S)	0.040	0.010
Alumium (Al)	—	0.035

- Note:
1. The selection of the actual steel grade shall be at the option of OneSteel unless otherwise negotiated and specified on the order.
  2. For special applications, alternative chemical compositions can be negotiated in some cases, and would be supplied to TS22.

**6.3 Mechanical Properties**

**6.3.1 Tensile Test**

Tubing in the As-Formed condition shall conform to the following tensile properties:

<b>TABLE 2 : MECHANICAL PROPERTIES</b>				
<b>D/t Ratio</b>	<b>&lt; 15</b>	<b>15 ≤ D/t &lt; 25</b>	<b>25 ≤ D/t &lt; 35</b>	<b>≥ 35</b>
Yield Strength MPa (min)	300	275	250	200
Tensile Strength MPa (min)	310	300	290	280
Elongation % (min)	15	20	25	30

where : D = outside diameter or equivalent round  
t = nominal wall thickness

- Note:
1. For special applications, alternative mechanical properties can be negotiated in some cases, and would be supplied to TS22

**6.3.2 Flare Test**

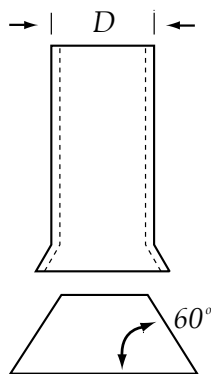

Both circular and non-circular tube shall be capable, with suitable end preparation, of being expanded over a cone or pyramid shaped drift expander until metal failure with no evidence of radial fracture of the weld zone, ie fracture of the weld zone along a radial line from the tube centre to the outside surface is not acceptable. A ductile/shear (45°) fracture of the weld zone or fracture of the parent metal is acceptable.

### 6.3.3 Flattening Tests

Circular tube shall be capable of being flattened without cracking between two parallel plane surfaces with the weld located at 90° and 0° to the direction of flattening until the distance between the surfaces is half the nominal outside diameter of the tube.

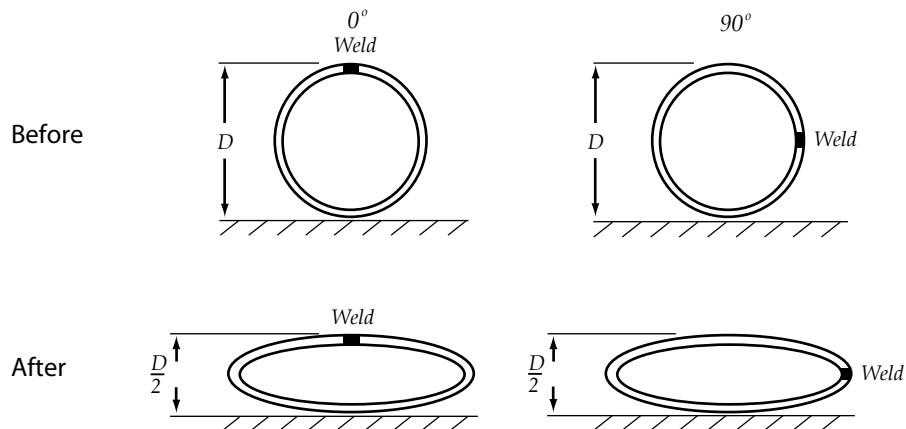

Note: 1. These tests are not applicable to non-circular tube

### 6.3.4 Special Requirements - Other Tests

By arrangement, tubing can be subjected to more severe flare and/or flattening tests or to other forms of mechanical testing such as bending and bulging.

### 6.4 Test Certificates

All tube deliveries shall be accompanied by a certificate of compliance to TS31. By arrangement, testing can be performed and certificates supplied.

**TABLE 3 : LEVELS OF CERTIFICATION**

Designation	Supply Condition
Standard	Certification of Compliance
T	Tested
TC	Test certificate supplied on request

The test certificates contain additional information on traceability, as well as chemical and mechanical test data.

**6.5 Surface Finish**

**6.5.1 Standard Surface Finishes**

Tube may be supplied with surface finishes as shown below:

<b>TABLE 4 : CQ AND BQ SURFACE FINISH – TS31</b>		
<b>Feature</b>	<b>Bright Quality (BQ)<sup>(1)</sup></b>	<b>Black<sup>(2)</sup> and Commercial Quality (CQ)</b>
Coil Break (Creases in Strip)	The surface shall be free of visual evidence of coil break.	Coil break up to 0.10mm deep shall not be cause for rejection.
Pitting	Isolated pits not exceeding 0.05mm deep shall not be cause for rejection.	Isolated pits not exceeding 0.15mm deep shall not be cause for rejection.
O.D. Scarfing	The external weld flash shall be cleanly removed to produce a smooth surface free of tool chatter marks.	The external weld flash shall be cleanly removed. Tool chatter marks up to 0.10mm deep shall not be cause for rejection.
Other Surface Marking <sup>(2)</sup>	Surface marking up to 0.05mm deep shall not be cause for rejection. <sup>(3)</sup>	Surface marking up to 0.10mm deep shall not be cause for rejection. <sup>(3)</sup>

Note: 1. Bright quality is suitable for applications where the surface finish is an important feature (eg. for subsequent plating). The amount of polishing required prior to plating will depend upon the standard of finish required.

2. The overall quality of the surface finish of black tubing will not be equivalent to tubing produced from cold rolled or pickled strip. Residual oxide from the hot rolling process will be present on the tube and may form a greasy film in combination with the rust preventative applied at the time of manufacture.

3. Other surface marking includes longitudinal roll marks, chop marks (quarter moon shaped roll marks), indentations due to metal pick up on weldmill tooling, scratches, reeler straightening marks, handling marks and weld burn (low frequency welding only).

**4. Notwithstanding the above table of possible defects, the overall appearance of the tube shall be consistent with good workmanship.**

**6.5.2 Other Special Requirements**

By arrangement, tubing can be supplied with restricted tolerances on certain surface finish features, eg depth of tool chatter on CQ tube

**6.6 Tube Dimensions & Wall Thickness**

**6.6.1 Outside Diameter - Circular Tube**

Circular tube shall be supplied to the following dimensional tolerances:

<b>TABLE 5 : OD TOLERANCES</b>	
<b>Outside Diameter, D (mm)</b>	<b>Maximum Permissible Variation in Outside Diameter, v (mm)</b>
$D \leq 16$	$\pm 0.10$
$16 < D \leq 25$	$\pm 0.15$
$25 < D \leq 50$	$\pm 0.20$
$50 < D \leq 75$	$\pm 0.25$
$75 < D \leq 100$	$\pm 0.30$
$100 < D \leq 125$	$\pm 0.35$

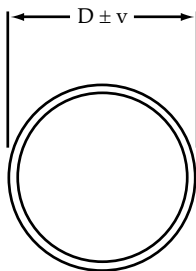

- Note:
1. If the wall thickness is less than 2.5% of the diameter, the above extreme tolerances shall be increased to 1.5 times the values shown.
  2. Due to the possible distortion of the tube on cutting, the outside diameter tolerance does not apply for a distance of 25 mm from the end of mill lengths (MLs) or non standard mill lengths (NSMLs) ie. on tube cut to length on the weldmill - refer to clause 6.9.
  3. As Formed ERW tube may change shape near the end of the tube due to the effects of welding and cutting when the tube is cut to the final required length.

### 6.6.2 Outside Dimensions - Non-Circular Tube

**TABLE 6 : OUTSIDE DIMENSIONAL TOLERANCES - NON-CIRCULAR TUBE**

Dimension, a (mm)	Maximum Permissible Variation in Diameter, v (mm)			
	Squares	Rectangles Long Side	Other Shapes	
			Long Side	Short Side
$a \leq 20$	$\pm 0.15$	$\pm 0.15$	$\pm 0.15$	$\pm 0.30$
$20 < a \leq 40$	$\pm 0.20$	$\pm 0.20$	$\pm 0.20$	$\pm 0.40$
$40 < a \leq 60$	$\pm 0.25$	$\pm 0.25$	$\pm 0.25$	$\pm 0.50$
$60 < a \leq 80$	$\pm 0.30$	$\pm 0.30$	$\pm 0.30$	$\pm 0.60$
$80 < a \leq 100$	$\pm 0.35$	$\pm 0.35$	$\pm 0.35$	$\pm 0.70$
$100 < a \leq 120$	$\pm 0.40$	$\pm 0.40$	$\pm 0.40$	$\pm 0.80$

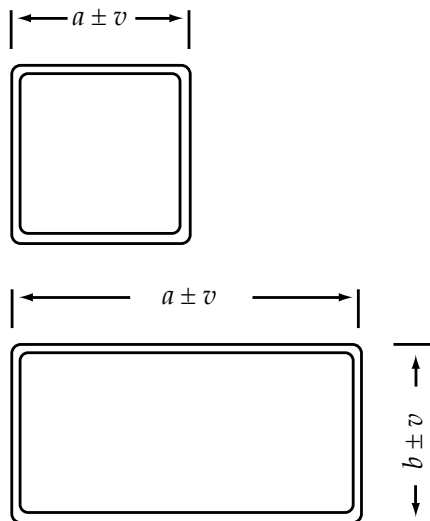

Note: 1. In the case of rectangles the tolerance shown for the long side shall also be applied to the short side (eg. the tolerances for 5025 rectangular tube shall be  $50.0 \pm 0.25\text{mm} \times 25.0 \pm 0.25\text{mm}$ ).

2. Due to the possible distortion of the tube on cutting, the tolerance shown does not apply for a distance of 25mm from the end of mill lengths (MLs) or non standard mill lengths (NSMLs) ie. on tube cut to length on the weldmill - refer to clause 6.9.

3. As Formed ERW tube may change shape near the end of the tube due to the effects of welding and cutting when the tube is cut to the final required length.

**6.6.3 Wall Thickness**

Tubing shall be supplied to the wall thickness tolerances as set out below:

<b>TABLE 7 : WALL THICKNESS TOLERANCE</b>	
<b>Wall Thickness, t (mm)</b>	<b>Maximum Permissible Variation in Wall Thickness, v (mm)</b>
$t \leq 1.0$	$\pm 0.10$
$1.0 < t \leq 1.6$	$\pm 0.15$
$1.6 < t \leq 2.0$	$\pm 0.20$
$2.0 < t \leq 3.0$	$\pm 0.25$
$3.0 < t \leq 4.0$	$\pm 0.30$
$4.0 < t \leq 5.0$	$\pm 0.35$
$5.0 < t \leq 6.0$	$\pm 0.40$

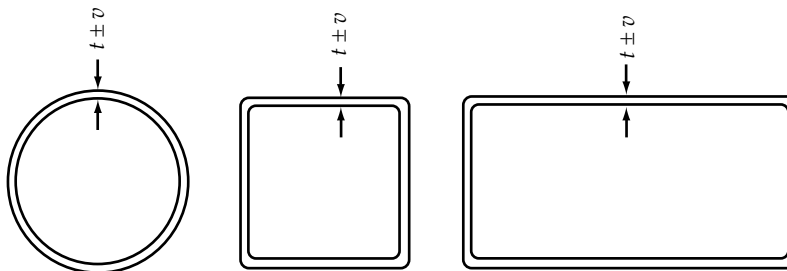

Note: 1. As localised thickening may occur, the above plus variations do not apply to the weld area as indicated by the width of the heat affected zone.

**6.6.4 Special Requirements - Tighter Dimensional Tolerances**

By arrangement, tubing can be supplied to tighter dimensional tolerances in some cases.

**6.7 Length**

**6.7.1 Mill Lengths**

Unless otherwise specified on the order, tubing shall be supplied in mill lengths (ML) of 6100 mm (6.1 metres), or by arrangement, tubing can be supplied ex the weldmill as a non-standard mill length (NSML) within the length range 4000 to 8000 mm eg. 5850 mm NSML. In both cases, a length tolerance of plus 50 mm minus Nil shall apply.

**6.7.2 Cut Lengths**

By arrangement, tubing can be supplied as cut lengths (CL). The tolerances applicable to length are:

<b>TABLE 8 : CUT LENGTH TOLERANCES</b>	
<b>Cut Length, CL (mm)</b>	<b>Max. Permissible Variation in Cut Length, v (mm)</b>
CL ≤ 1000	+ 1.0, - Nil
1000 < CL ≤ 2000	+ 1.5, - Nil
2000 < CL ≤ 4000	+ 3.0, - Nil
4000 < CL ≤ 6000	+ 4.5, - Nil
CL > 6000	+ 6.0, - Nil

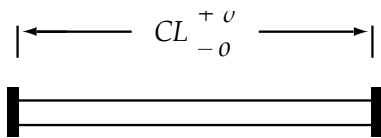

Note: 1. The tube length shall be taken to be the measured distance between two parallel plates in contact with each end of the tube. This could vary from the overall length measured along the outside of the tube using a micrometer, vernier or similar device due to the tolerance for end squareness.

**6.7.3 Special Requirements - Tighter Length Tolerances**

By arrangement, tubing can be supplied to tighter length tolerances in some cases.

**6.7.4 End Squareness**

End squareness shall be expressed as the maximum deviation that can be measured between the end of the tube and a straight edge in contact with the end of the tube and at right angles to the tube axis. The maximum allowable out of squareness shall be 0.05 mm per 10 mm of O.D. (equivalent to 0.3°). End squareness shall apply only to cut lengths up to 1000 mm.

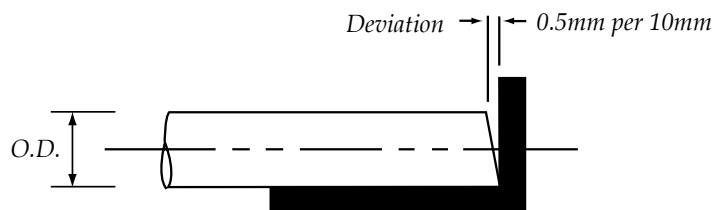

**6.8 Height of Weld Upset**

**6.8.1 Normal Fin**

The external weld upset shall be removed completely ie. flush with the outside surface of the tube.  
 The internal weld upset or fin is not normally removed and the height may measure up to 1.0 mm or 50% of the nominal wall thickness whichever is the greater. This condition is designated Normal Fin (NF).

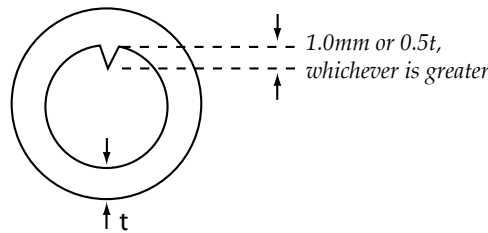

**6.8.2 Special Requirements - Fin Cut**

By arrangement, the internal weld upset or fin on certain sizes can be removed in accordance with the following standards:

<b>TABLE 9 : FIN CONDITION</b>			
<b>Designation</b>	<b>Abbrev.</b>	<b>Wall Thickness, t (mm)</b>	<b>Internal Fin Height <sup>(1)</sup> (mm)</b>
Fin Cut	FC	All	+ 0.40 <sup>(2)</sup>
Fully Fin Cut	FFC	All	± 0.10 <sup>(2)</sup>
Flush to Undercut	FTUC	t < 1.6mm	+ Nil, - 0.15
		1.6 ≤ t ≤ 4.0	+ Nil, - 10% of t
		t > 4.0	+ Nil, - 0.40 <sup>(3)</sup>

- Note:
1. The above tolerances are measured in relation to the wall thickness adjacent to the weld.
  2. In the case of FC and FFC any undercut must not reduce the tube wall thickness below the specified minimum.
  3. In the case of FTUC, it should be noted that the undercutting may reduce the actual wall thickness below the specified minimum.

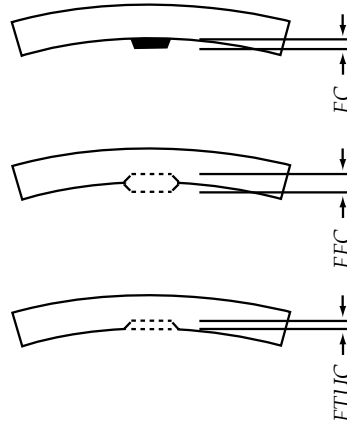

### 6.9 End Condition

#### 6.9.1 Mill Lengths

Tube shall be supplied with shear or saw cut mill ends that may have a small shear dimple or burrs.

#### 6.9.2 Cut Lengths

Cut lengths can be supplied with the following specific end conditions:

##### (a) As Cut

Tube ends will be as cut by shear, saw, laser or lathe and some cutting burr could remain.

##### (b) Deburred

Safe to handle and no dimensional evidence of burr on the outside or inside of the tube. The aim is to completely remove the external and internal burr with minimum stock removal. Unless otherwise specified, there may be evidence of a burr on the end face. Tool chatter is to be avoided but shall not be cause for rejection (workmanship).

##### (c) Chamfer

The tube end shall be tool cut on the external and/or internal surface of the tube end to the following dimensions (unless otherwise negotiated and specified on the order).

Angle of Chamfer	=	$30^{\circ} \pm 5^{\circ}$
Min. Length of Chamfer	=	0.10 mm
Max. Length of Chamfer	=	2.10 mm

Stock removal - at least 50% of nominal wall thickness shall remain after internal and/or external chamfering. Tool chatter - shall be avoided but shall not be cause for rejection (workmanship).

- Note:
1. Cut lengths specified as Deburred may be supplied in the Chamfered condition.
  2. Other specific end finishing requirements can be supplied subject to enquiry.

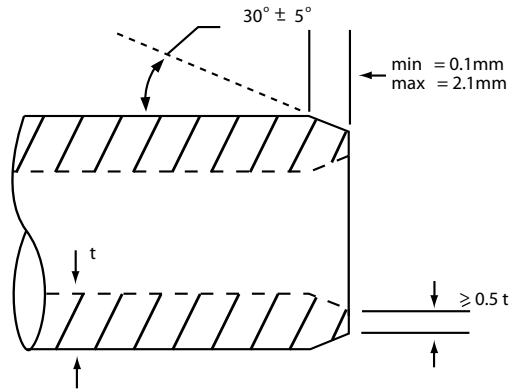

**6.10 End Welds (Cross Welds)**

Tubes containing the cross welds used to join the end of one coil of strip to the next shall not be included in the consignment.

**6.11 Straightness**

For lengths greater than or equal to 1000 mm the straightness tolerance shall be as shown in the table below, which assumes the tube to be bent in a constant radius, measured against a straight edge.

For lengths less than 1000 mm the straightness tolerance shall be 1.0mm maximum deviation.

TABLE 10 : STRAIGHTNESS TOLERANCE									
Length (mm)	1,000	2,000	3,000	4,000	5,000	6,000	6,100	7,000	8,000
Tolerance (mm)	1.0	1.1	2.5	4.4	6.9	10.0	10.3	13.6	17.8

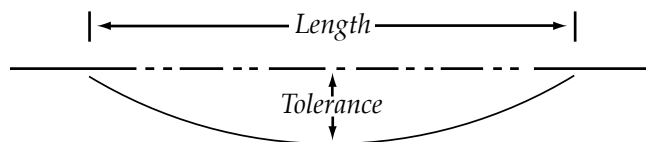

By arrangement, tube with other straightness tolerances can be supplied in some cases.

**6.12 Non-Circular Tube - Other Features**

**6.12.1 Corner Radii**

Corner radii differ for each size and wall thickness combination. Typical corner radii information can be supplied on request.

**6.12.2 Weldline Location**

Due to the configuration of the weldmill rolls, the weldline will normally be equidistant from the opposite corners ie. the weldline will be on or adjacent to a corner in the case of squares and on the longer face in the case of rectangles, ovals and flat sided ovals.

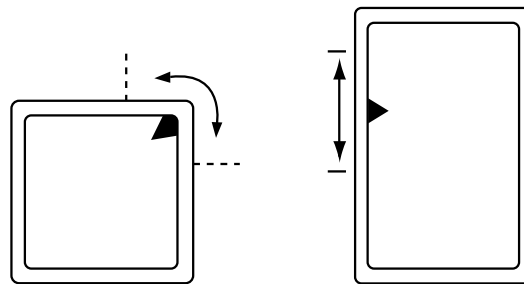

No action is normally taken to control the exact location of the weldline. However, where weldline location is a critical feature this should be the subject of an enquiry.

**6.12.3 Twist**

The tolerances for twist of non-circular tubing are shown in the table below:

<b>TABLE 11 : TWIST TOLERANCE</b>	
<b>Largest Dimension, a (mm)</b>	<b>Twist Tolerance in 1 metre, v (mm)</b>
$a \leq 12.7$	0.9
$12.7 < a \leq 38.1$	1.4
$38.1 < a \leq 63.5$	1.7
$63.5 < a \leq 101.6$	2.1

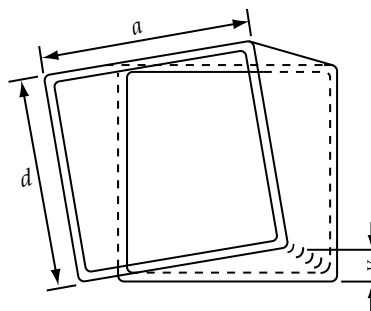

**6.12.4 Squareness - Square & Rectangular Tube**

Maximum out of square of adjacent sides shall be 0.10 mm in 10 mm face width (equivalent to 0.6°).

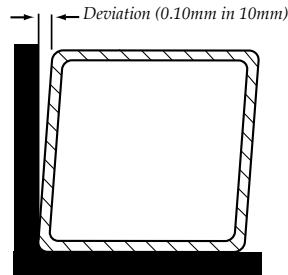

**6.12.5 Flatness - Square, Rectangular and Flat Sided Oval Tube**

The actual dimensional variation across any face shall not exceed half of the total outside dimensional tolerance as set out in clause 6.6.2.

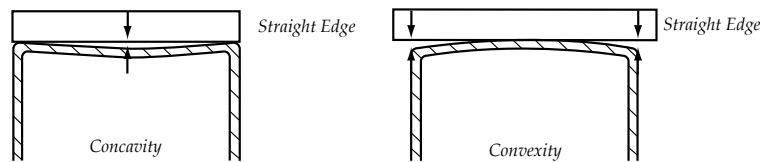

**6.13 Rust Prevention**

**6.13.1 Standard Rust Prevention**

The tube shall be coated with a light, readily removable, temporary rust preventative, designed to withstand corrosion when stored in normal conditions under cover for at least 3 months from time of delivery.

**6.13.2 Other Rust Prevention**

By arrangement, tube may be supplied with greater or lesser amounts of rust preventative in some cases.

**6.13.3 No Added Oil**

By arrangement, tube can be supplied with no temporary rust preventative added.

- Note:
1. The possibility of corrosion of tube in this state will be greater, and instances of corrosion shall not be cause for rejection.
  2. Residual oils from the manufacturing process may be present.

**6.14 Packaging**

Standard packaging for mill lengths and some cut lengths is batten-strapped, rectangular or hexagonal packs.

Note:

1. By arrangement, other packaging options may be available. For example, stillages may be used to supply cut lengths, and large diameter tubing may be supplied in crates.
2. Standard rectangular pack sizes for mill lengths are described in the Dimensions and Properties section of the BTM<sup>®</sup> Customer Information Handbook. Different pack sizes shall be the subject of agreement between the customer and the supplier.

**6.15 Special Requirements**

Any other requirements not covered by the above clauses should be the subject of any enquiry prior to placement of an order.

**7.0 Control**

This specification is not to be reproduced without the authority of the originator.  
Holders of this specification should determine its validity prior to use.

# BTM<sup>®</sup> TUBE PRODUCTS

**Technical specifications are also available for the following BTM<sup>®</sup> Precision Tubing products:**

<b>TS 11</b>	Black (hot rolled) ERW steel tubing for general applications
<b>TS 21</b>	Low carbon ERW steel tubing for general applications(EzyForm™)
<b>TS 22</b>	ERW steel tubing with specified mechanical properties(Hi-Lite®)
<b>TS 28</b>	Low carbon ERW Hi-Form® and Hi-Form®(Aluminised) steel tubing for use in automotive exhaust systems
<b>TS 30</b>	Low carbon ERW BTM <sup>®</sup> GALVATUBE™ steel tubing for general applications
<b>TS 31</b>	Low carbon ERW steel tubing with special requirements
<b>TS 41</b>	Low carbon ERW steel tubing for fluid carrying applications.
<b>TS 50</b>	Powder coated ERW steel tubing(Tubecolor®).

**OneSteel has a range of other Technical Specifications for products and/or applications not listed above. Please contact OneSteel Direct for further Information or visit our website [www.onesteel.com](http://www.onesteel.com)**



## ONESTEEL DIRECT

Freecall 1800 178 335

Website [www.onesteel.com](http://www.onesteel.com)

Freefax 1800 101 141

Email [onesteeldirect@onesteel.com](mailto:onesteeldirect@onesteel.com)

This publication has been prepared by OneSteel, (OneSteel Trading Pty Limited ABN 50 007 519 646). Please note that the specifications and technical data are subject to change without notice and to ensure accuracy users of this publication are requested to check the information to satisfy themselves and not to rely on the information without first doing so. Unless required by law the company cannot accept any responsibility for any loss, damage or consequence resulting from the use of this publication. Photographs shown are representative only of typical applications, current at May 2007. This brochure is not an offer to trade and shall not form any part of the trading terms in any transaction. Issue 4 May 2007. Copyright 2004-07. OneSteel Trading Pty Limited ABN 50 007 519 646 Registered Trademarks: BTM<sup>®</sup>, Tubecolor<sup>®</sup>, Hi-Form<sup>®</sup>, EzyForm<sup>™</sup> and GALVATUBE<sup>™</sup>. DuraGal<sup>®</sup> is a registered Trademark of Australian Tube Mills Pty Limited ACN 123 160 172. BC0407

DISTRIBUTED BY