

KNOW YOUR STEEL

Steel Reference Guide



BUILDING AUSTRALIA
WITH YOU

JANUARY 2010

NATIONAL PROCESSING SOLUTIONS



COMBINING QUALITY PRODUCT, TECHNICAL EXPERTISE & PROJECT MANAGEMENT

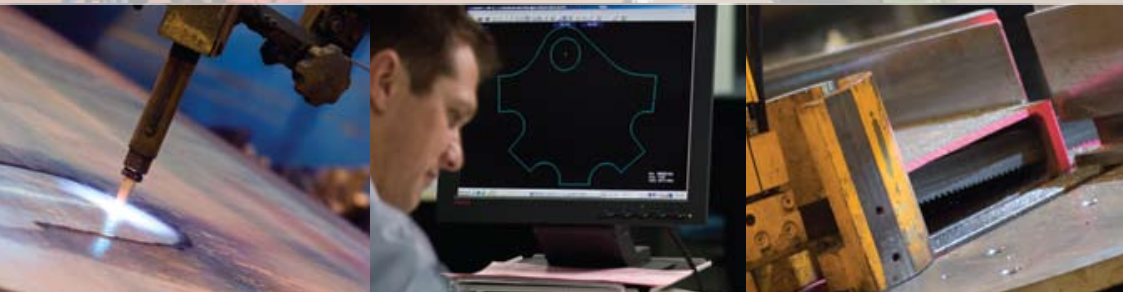

OneSteel Steel & Tube is a major national steel processing provider, as well as a leading steel distributor. We offer customised processing solutions inclusive of an extensive range of additional services, reducing the complexity for you. If you have a major project, contact OneSteel Steel & Tube to find out how you can maximise the quality of results with one of our complete processing packages.

The Full Processing Package

Our processing packages draw on all of our available resources, including staged planning, dedicated supply, expedited business tools, material traceability and logistics management. Our national footprint means we can supply solutions for you, wherever you need them. We are able to offer direction on alternate product specifications and provide cost savings through waste minimisation. Importantly, you get a full processing package that is delivered with the calibre of service that only a national operator like us can offer.

Matching Your Needs

To ensure your project runs smoothly, we can customise a processing solution to match your needs. We provide you with a dedicated internal processing team, comprised of estimators, programmers, design engineers, project managers, skilled operators, warehouse coordinators, safety managers and logistics experts. Our state-of-the-art programming software allows us to optimise compatibility with your business. With our team's technical skill and processing expertise, OneSteel Steel & Tube can help deliver a quality result for your project.

HEAD OFFICE

Sydney

Level 6, 205 Pacific Highway St Leonards 2065

Locked Bag 3050 Artarmon NSW 1570

e stenquiries@onesteel.com

w onesteel.com/steelandtube



NEW SOUTH WALES

Sydney

372-374 Victoria Street, Wetherill Park NSW 2164

T+61 2 9203 2222

F+61 2 9203 2266

e wpksales@onesteel.com

Wollongong

Five Islands Road, Unanderra NSW 2526

T+61 2 4271 1788

F+61 2 4271 7198

e wolsales@onesteel.com

Newcastle

Industrial Drive, Mayfield NSW 2304

T+61 2 4967 0900

F+61 2 4967 0970

e newcastlesales@onesteel.com

VICTORIA

Melbourne

1257-1259 Ferntree Gully Road, Scoresby VIC 3179

T+61 3 9212 7800

F+61 3 9764 1456

e victoriasales@onesteel.com

Geelong

Cnr. Broderick & Heales Roads, Corio VIC 3215

T+61 3 5274 1414

F+61 3 5275 0321

e geesls@onesteel.com

WESTERN AUSTRALIA

Perth

Lot 302 Spearwood Avenue, Bibra Lake WA 6163

T+61 8 9418 9877

F+61 8 9418 6013

e steel&tubewa@onesteel.com

QUEENSLAND

Brisbane

692 Boundary Road, Coopers Plains QLD 4108

T+61 1300 302 317

F+61 7 3277 5814

e cplsales@onesteel.com

Mackay

Cnr. Harbour Road & Spiller Avenue, North Mackay QLD 4740

T+61 7 4955 1555

F+61 7 4955 2606

e salesmackay@onesteel.com

Townsville

387 Bayswater Road, Townsville QLD 4814

T+61 7 4775 6111

F+61 7 4725 4601

e towsales@onesteel.com

SOUTH AUSTRALIA

Adelaide

13 Webb St, Port Adelaide SA 5015

T+61 8 8300 3333

F+61 8 8300 3366

e sasteel@onesteel.com

NORTHERN TERRITORY

Darwin

Lot 889 Stuart Highway, Berrimah NT 0828

T+61 8 8935 0350

F+61 8 8935 0380

e darsales@onesteel.com

OneSteel Steel & Tube, Issued January 2010

This publication has been prepared by OneSteel Steel & Tube, an operating business group of OneSteel Distribution, OneSteel Trading Pty Limited ABN 50 007 519 646. Please note that any specifications or technical data referred to in this publication are subject to change and/or variation or improvement without notice and no warranty as to their suitability for any use is made. Users of this publication - to ensure accuracy and adequacy for their purposes - are requested to check the information provided in this publication to satisfy themselves as to its appropriateness and not to rely on the information without first doing so. Unless required by law, the company does not accept any responsibility for any loss, damage or consequence resulting from the use of or reliance upon this publication. This publication is not an offer to trade and shall not form any part of the trading terms in any transaction. Images reproduced courtesy of Bucyrus International Inc. CAOSST10 © Copyright 2010 OneSteel Trading Pty Limited. Not to be reproduced in any form.

Foreword

This publication has been prepared by OneSteel Steel & Tube which is an operating business group of OneSteel Distribution, OneSteel Trading Pty Limited ABN 50 007 519 646.

The aim of this booklet is to provide customers with useful information regarding Australian steel. Every effort has been made to ensure that the information contained in this publication is accurate.

However, it should be noted that the company cannot accept responsibility for errors or omissions, or for changes which have taken place since the printing of this edition. Unless required by law, the company cannot accept any responsibility for any loss, damage or consequence resulting from the use of this publication.

The preferred range of sizes only has been covered, some of these sizes may be subject to minimum order quantities, and every care should be taken to establish availability before proceeding based on the specifications provided. Additional information concerning non-preferred sizes, range of specifications available, or related data not included in this booklet is available on request through OneSteel Steel & Tube sites. Contact details are available on the previous page of this booklet.

Note: Mass Calculations have been based on a mass for carbon steel of 7,850 kg/m³ rounded off and include a 2.5 per cent rolling tolerance where applicable.

Sources

- OneSteel - Pricing and Availability Guide - Hot Rolled & Welded Structural Steel (Effective 3rd September 2009); Pricing and Availability Guide - Merchant Bar Products (Effective 4th September 2009); Pricing and Availability Guide - Precision Tube Products (Effective 5th October 2009)
- OneSteel Reinforcing Price & Availability Guides (Effective January 2009)
- Midalia Steel Price List (September 2005)
- Australian Tube Mills - Pricing and Availability Guide - Pipe & Tube Structural Products (Effective 1st September 2009); Pricing and Availability Guide - DuraGal® Profiles (Effective 16th September 2009)
- BTM Information Handbook (Date of Issue: 19/03/03 Issue 2)
- Nationwide Stainless Weights (2009)
- BlueScope Steel - Xlerplate® General Range Price Schedule (Effective 6th June 2008)
- BlueScope Steel - Xlerplate® Coil Plate & Coil Floor Plate Price Schedule (Effective 6th June 2008)

Trademarks

Registered trademarks of OneSteel Trading Pty Ltd: DuraGal®, SupaGal® Galtube Plus®, DuraGal Flooring System®, DuraGal Carport®, EZYFORM®, HI-FORM®, GALVATUBE®, TUBECOLOR®, HI-LITE®

Registered trademarks of OneSteel Manufacturing Pty Ltd: 300PLUS®

Registered trademarks of OneSteel Reinforcing Pty Ltd: HANDI MESH®

Registered trademarks of OneSteel Coil Coaters Pty Ltd: COLORGUARD®

Trademarks of OneSteel Trading Pty Ltd: GAL140™

Trademarks of OneSteel Australian Tube Mills Pty Ltd: OZTUBE™

Registered Trademarks of LiteSteel Products Pty Ltd: LiteSteel® beam

Registered trademarks of BlueScope Steel Ltd: BLACKFORM®, BRIGHTFORM®, GALVABOND®, GALVASKIN®, ZINCANNEAL®, ZINCALUME®, COLORBOND®, LY-TEN®

Trademark of BlueScope Steel Ltd: Lasercut™

Registered trademark of ITW Australia Pty Ltd: PRYDA®

Flat Bar* - Square Edge

6m



Size mm x mm			Mass kg/m	Metres per Tonne	Size mm x mm			Mass kg/m	Metres per Tonne
20	x	3	0.48	2070	65	x	3	1.57	637
	x	5	0.81	1242		x	5	2.62	382
	x	6	0.97	1035		x	6	3.14	319
	x	10	1.61	622		x	8	4.18	239
25	x	3	0.60	1658		x	10	5.23	191
	x	5	1.01	994		x	12	6.28	159
	x	6	1.21	829		x	16	8.37	120
	x	8	1.61	622		x	20	10.5	95.6
	x	10	2.01	497		x	25	13.1	76.5
	x	12	2.41	414		75	x	5	3.02
32	x	3	0.77	1295	x		6	3.62	276
	x	5	1.29	777	x		8	4.83	207
	x	6	1.55	647	x		10	6.04	166
	x	8	2.06	485	x		12	7.24	138
	x	10	2.58	388	x		16	9.66	104
	x	12	3.09	324	x		20	12.1	82.9
40	x	3	0.97	1035	x		25	15.1	66.3
	x	5	1.61	622	x		40	24.1	41.4
	x	6	1.93	518	90		x	5	3.62
	x	8	2.58	388		x	6	4.35	230
	x	10	3.22	311		x	8	5.79	173
	x	12	3.86	259		x	10	7.24	138
	x	16	5.15	194		x	12	8.69	115
	x	20	6.44	159		100	x	5	4.02
50	x	3	1.21	829	x		6	4.83	207
	x	5	2.01	497	x		8	6.44	155
	x	6	2.41	414	x		10	8.05	124
	x	8	3.22	311	x		12	9.66	104
	x	10	4.02	249	x		16	12.9	77.7
	x	12	4.83	207	x		20	16.1	62.1
	x	16	6.44	155	x		25	20.1	49.7
	x	20	8.05	124	x	50	40.2	24.9	
	x	25	10.1	99.4					

* OneSteel typically carries Grade 300 & 1045
Packs are offered in nominal 2 tonne bundles

Flat Bar* - Square Edge

6m —

Size mm x mm	Mass kg/m	Metres per Tonne	Size mm x mm	Mass kg/m	Metres per Tonne
110 x 6	5.31	188	180 x 12	17.4	57.5
x 8	7.08	141	x 16	23.2	43.2
x 10	8.85	113	x 20	29.0	34.5
x 12	10.6	94.2	x 25	36.2	27.6
130 x 5	5.23	191	200 x 6	9.66	104
x 6	6.28	159	x 8	12.9	77.7
x 8	8.37	120	x 10	16.1	62.1
x 10	10.5	95.6	x 12	19.3	51.8
x 12	12.6	79.7	x 16	25.7	38.8
x 16	16.7	59.8	x 20	32.2	31.1
x 20	20.9	47.8	x 25	40.3	24.9
x 25	26.2	38.2	250 x 6	12.1	82.9
150 x 5	6.04	166	x 8	16.1	62.2
x 6	7.24	138	x 10	20.1	49.7
x 8	9.66	104	x 12	24.1	41.4
x 10	12.1	82.9	x 16	32.2	31.1
x 12	14.5	69.1	x 20	40.2	24.9
x 16	19.3	51.8	x 25	50.3	19.9
x 20	24.1	41.4	300 x 6	14.5	69.1
x 25	30.1	33.1	x 8	19.3	51.8
x 50	60.4	16.6	x 10	24.1	41.4
180 x 5	7.24	138	x 12	29.0	34.5
x 6	8.69	115	x 16	38.6	25.9
x 10	14.5	69.1	x 20	48.3	20.7
			x 25	60.4	16.6

Flat Bar* - Round Edge

4m —

Size mm x mm	Mass kg/m	Metres per Tonne	Size mm x mm	Mass kg/m	Metres per Tonne
10 x 3	0.24	4132	16 x 3	0.39	2590
13 x 3	0.31	3185	x 5	0.64	1552
x 5	0.52	1912	x 8	1.03	971
x 6	0.63	1592			

* OneSteel typically carries Grade 300 & 1045
Packs are offered in nominal 2 tonne bundles



Size mm	Nominal Thickness mm	Mass kg/m	Metres per Tonne	Pack Size (Lns)	Size mm	Nominal Thickness mm	Mass kg/m	Metres per Tonne	Pack Size (Lns)
50	4	1.49	671	57	150	5	5.53	181	28
	5	1.84	543	45		6	7.07	142	24
65	4	1.94	515	44		8	9.42	106	22
	5	2.40	417	36	200	5	7.38	136	32
75	4	2.24	447	38		6	9.42	106	28
	5	2.77	361	32	8	12.6	79.6	22	
100	4	2.98	336	28	250	5	9.22	108	23
	5	3.69	271	28		8	15.7	63.7	16
130	6	4.71	212	26	300	5	11.1	90.1	19
	8	6.28	160	22		8	18.8	53.1	12
	5	4.80	208	28					



Diameter mm	Mass kg/m	Metres per Tonne	Diameter mm	Mass kg/m	Metres per Tonne
10	0.64	1563	56	19.8	50
12	0.92	1087	60	22.8	44
14	1.24	806	65	26.7	37
16	1.62	617	75	35.6	28
18	2.05	488	80	40.5	24
20	2.53	395	90	51.2	20
22	3.06	327	100	63.2	16
24	3.65	274	110	76.5	13
27	4.61	217	120	91.0	11
30	5.69	176	130	107	9.4
33	6.89	145	140	124	8.1
36	8.20	122	150	142	7.0
39	9.62	104	160	162	6.2
42	11.15	90	170	182	5.5
45	12.80	78	180	205	4.9
48	14.57	69	190	229	4.4
50	15.80	63	200	253	4.0

* OneSteel typically carries Grade 300 & 1045
Packs are offered in nominal 2 tonne bundles

Square Bar* 6m

Size mm x mm	Mass kg/m	Metres per Tonne
10 x 10	0.81	1235
12 x 12	1.16	862
16 x 16	2.06	485
20 x 20	3.22	311
25 x 25	5.03	219
32 x 32	8.24	121
40 x 40	12.8	78

Billets* 6m

Size mm x mm	Mass kg/m	Metres per Tonne
45 x 45	16.30	61
50 x 50	27.80	36
63 x 63	31.20	32
75 x 75	45.27	22

Angles - 300PLUS® Equal

Various Standard
Lengths 

Size mm x mm	Mass kg/m	Metres per Tonne
20 x 20 x 3	0.95	1053
25 x 25 x 3	1.12	893
x 5	1.65	606
x 6	2.08	481
30 x 30 x 3	1.35	741
x 5	2.01	498
x 6	2.56	391
40 x 40 x 3	1.83	546
x 5	2.73	366
x 6	3.50	286
45 x 45 x 3	2.06	485
x 5	3.10	323
x 6	3.97	252
50 x 50 x 3	2.31	433
x 5	3.48	287
x 6	4.46	224
x 8	5.68	176
55 x 55 x 5	3.84	260
x 6	4.93	203
65 x 65 x 5	4.56	219
x 6	5.87	170
x 8	7.51	133
x 10	9.02	111

Size mm x mm	Mass kg/m	Metres per Tonne
75 x 75 x 5	5.27	190
x 6	6.81	147
x 8	8.73	115
x 10	10.5	95
90 x 90 x 6	8.22	122
x 8	10.6	94
x 10	12.7	79
100 x 100 x 6	9.16	109
x 8	11.8	85
x 10	14.2	70
x 12	17.7	57
125 x 125 x 8	14.9	67
x 10	18.0	56
x 12	22.5	44
x 16	29.1	34
150 x 150 x 10	21.9	46
x 12	27.3	37
x 16	35.4	28
x 19	42.1	24
200 x 200 x 13	40.0	25
x 16	48.7	21
x 18	54.4	18
x 20	60.1	17
x 26	76.8	13

* OneSteel typically carries Grade 300 & 1045
Packs are offered in nominal 2 tonne bundles

Angles - DuraGal®

Various Standard Lengths



Size mm	Nominal Thickness mm	Mass kg/m	Metres per Tonne	Length/ Pack		Size mm	Nominal Thickness mm	Mass kg/m	Metres per Tonne	Length/ Pack	
				Standard						9.0	12
				6.0	9.0						
30 x 30	2.5	1.06	947	80		75 x 75	6.0	6.56	152	18	
40 x 40	2.5	1.43	699	60		90 x 90	8.0	8.59	116	18	
	4.0	2.20	455	39			5.0	6.37	157	22	
45 x 45	2.5	1.62	617	54		100 x 100	8.0	10.5	95.2	18	
	4.0	2.50	400	36			6.0	8.92	112		16
50 x 50	2.5	1.81	553	33	33	125 x 125	8.0	11.7	85.5		14
	4.0	2.80	357	27	27		4.0	7.27	138		20
	5.0	3.40	294		24		5.0	8.95	112		18
	6.0	4.21	238		21		8.0	14.9	67.1		12
65 x 65	4.0	3.69	271		22	150 x 150	5.0	10.8	92.6		18
	5.0	4.51	222		22		8.0	18.0	55.6		12
	6.0	5.62	178		18						
75 x 75	4.0	4.29	233		22						
	5.0	5.25	190		22						

Angles - 300PLUS® Unequal

Various Standard Lengths



Size mm x mm	Mass kg/m	Metres per Tonne	Size mm x mm	Mass kg/m	Metres per Tonne
65 x 50 x 5	4.02	249	125 x 75 x 6	9.16	109
x 6	5.16	194	x 8	11.8	85
x 8	6.59	152	x 10	14.2	70
			x 12	17.7	57
75 x 50 x 5	4.40	227			
x 6	5.64	177	150 x 90 x 8	14.3	70
x 8	7.21	139	x 10	17.3	58
			x 12	21.6	46
100 x 75 x 6	7.98	125	x 16	27.9	36
x 8	10.3	97			
x 10	12.4	81	150 x 100 x 10	18.0	56
			x 12	22.5	44

Channels - DuraGal®

Various Standard
Lengths



Size mm	Nominal Thickness mm	Mass kg/m	Metres per Tonne	Length/ Pack	
				Standard	
				9.0	12
75 x 40	4.0	4.25	235	18	
100 x 50	4.0	5.59	179	18	
125 x 65	4.0	7.23	138	18	
150 x 75	5.0	10.5	95.1		12
180 x 75	5.0	11.6	86.2		12

Size mm	Nominal Thickness mm	Mass kg/m	Metres per Tonne	Length/ Pack	
				Standard	
				9.0	12
200 x 75	5.0	12.4	80.7		12
	6.0	15.5	64.6		12
230 x 75	6.0	16.9	59.2		12
250 x 90	6.0	19.2	52.1		8
300 x 90	6.0	21.6	46.3		6
	8.0	28.5	35.1		6

Channels - 300PLUS® Parallel Flange

Various Standard
Lengths



Size mm x mm	Mass kg/m	Metres per Tonne
50 x 25*	4.50	222
75 x 40	5.92	169
100 x 50	8.33	120
125 x 65	11.9	84.0
150 x 75	17.7	56.5
180 x 75	20.9	47.9

Size mm x mm	Mass kg/m	Metres per Tonne
200 x 75	22.9	43.7
230 x 75	25.1	39.8
250 x 90	35.5	28.2
300 x 90	40.1	24.9
380 x 100	55.2	18.1

*Taper Flange Channel

Rails



Section	Mass kg/m	Metres per Tonne
10	10.10	99.00
15	15.20	65.79
22	22.30	44.84
30	30.10	33.22
41	40.80	24.51
50	50.60	19.76

Section	Mass kg/m	Metres per Tonne
53	53.00	18.87
60	60.60	16.50
68	67.50	14.81
73	73.63	13.58
86	85.50	11.70

Rails are not normally a stocked item - Lead times may apply

Beams - 300PLUS® Universal

Various Standard
Lengths



Metric Designation	Size mm x mm	Mass kg/m	Metres per Tonne
150 UB	150 x 75	14.0	71
	155 x 75	18.0	56
180 UB	173 x 90	16.1	62
	175 x 90	18.1	55
	179 x 90	22.2	45
200 UB	198 x 99	18.2	55
	202 x 133	22.3	45
	203 x 133	25.4	39
	207 x 134	29.8	34
250 UB	248 x 124	25.7	39
	252 x 146	31.4	32
	256 x 146	37.3	27
310 UB	298 x 149	32.0	31
	304 x 165	40.4	25
	307 x 166	46.2	22

Metric Designation	Size mm x mm	Mass kg/m	Metres per Tonne
360 UB	352 x 171	44.7	22
	356 x 171	50.7	20
	359 x 172	56.7	18
410 UB	403 x 178	53.7	19
	406 x 178	59.7	17
460 UB	454 x 190	67.1	15
	457 x 190	74.6	13
	460 x 191	82.1	12
530 UB	528 x 209	82.0	12
	533 x 209	92.4	11
610 UB	602 x 228	101	10
	607 x 228	113	9
	612 x 229	125	8

Beams - 300PLUS® Welded

Various Standard
Lengths



Metric Designation	Size mm x mm	Mass kg/m	Metres per Tonne
700 WB	692 x 250	115	8.70
	700 x 250	130	7.69
	710 x 250	150	6.67
	716 x 275	173	5.78
800 WB	792 x 250	122	8.20
	800 x 275	146	6.85
	810 x 275	168	5.95
	816 x 300	192	5.21
900 WB	900 x 300	175	5.71
	910 x 350	218	4.59
	916 x 400	257	3.89
	924 x 400	282	3.55

Metric Designation	Size mm x mm	Mass kg/m	Metres per Tonne
1000 WB	1000 x 300	215	4.65
	1010 x 350	258	3.88
	1016 x 400	296	3.38
	1024 x 400	322	3.11
1200 WB	1170 x 275	249	4.02
	1170 x 350	278	3.60
	1176 x 400	317	3.15
	1184 x 400	342	2.92
	1184 x 500	392	2.55
	1192 x 500	423	2.36
	1200 x 500	455	2.20

Beams - 300PLUS® Taper Flange

Various Standard
Lengths



Size mm x mm	Mass kg/m	Metres per Tonne	Size mm x mm	Mass kg/m	Metres per Tonne
100 x 45	7.20	139	125 x 65	13.1	76.0

Columns - 300PLUS® Universal

Various Standard
Lengths



Metric Designation	Size mm x mm	Mass kg/m	Metres per Tonne	Metric Designation	Size mm x mm	Mass kg/m	Metres per Tonne	
100 UC	97 x 99	14.8	68	250 UC	254 x 254	72.9	14	
						260 x 256	89.5	11
150 UC	152 x 152	23.4	43	310 UC	308 x 305	96.8	10	
	158 x 153	30.0	33			315 x 307	118	8
	162 x 154	37.2	27			321 x 309	137	7
200 UC	203 x 203	46.2	22			327 x 311	158	6
	206 x 204	52.2	19					
	210 x 205	59.5	17					

Columns - 300PLUS® Welded

Various Standard
Lengths



Metric Designation	Size mm x mm	Mass kg/m	Metres per Tonne	Metric Designation	Size mm x mm	Mass kg/m	Metres per Tonne	
350 WC	331 x 350	197	5.08	500 WC	490 x 500	228	4.39	
	339 x 350	230	4.35			500 x 500	267	3.75
	347 x 350	258	3.88			506 x 500	290	3.45
	355 x 350	280	3.57			514 x 500	340	2.94
400 WC						472 x 500	383	2.61
	382 x 400	144	6.94			480 x 500	414	2.42
	390 x 400	181	5.52			480 x 500	440	2.27
	400 x 400	212	4.72					
	414 x 400	270	3.7					
	422 x 400	303	3.3					
	430 x 400	328	3.05					
	430 x 400	361	2.77					

Hot Rolled Structural Standard Bundle Configuration

Channels	kg/m	6.0-9.0 m	9.1-10.5 m	10.6-12.0 m	12.1-13.5 m	13.6-15.0 m	15.1-16.5 m	16.6-18.0 m
150 PFC	17.7	30	24	20	20	16	16	12
180 PFC	20.9	24	20	16	16	12	12	12
200 PFC	22.9	24	20	16	16	12	12	12
230 PFC	25.1	20	16	16	12	12	12	10
250 PFC	35.5	12	12	8	8	8	8	8
300 PFC	40.1	12	8	8	8	8	6	6
380 PFC	55.2	10	8	6	6	6	4	4

Angles	kg/m	6.0-9.0 m	9.1-10.5 m	10.6-12.0 m	12.1-13.5 m	13.6-15.0 m
125 x 125 x 8	14.9	36	30	26	21	21
125 x 125 x 10	18.0	30	25	22	18	18
125 x 125 x 12	22.5	24	20	18	14	14
125 x 125 x 16	29.1	19	16	14	11	11
150 x 90 x 8	14.3	36	30	27	21	21
150 x 90 x 10	17.3	32	27	24	19	19
150 x 90 x 12	21.6	24	21	18	15	15
150 x 90 x 16	27.9	19	16	14	11	11
150 x 100 x 10	18.0	30	25	22	18	18
150 x 100 x 12	22.5	24	20	18	14	14
150 x 150 x 10	21.9	25	21	18	15	15
150 x 150 x 12	27.3	20	16	15	12	12
150 x 150 x 16	35.4	15	13	11	9	9
150 x 150 x 19	42.1	13	11	9	7	7
200 x 200 x 13	40.0	13	11	10	8	8
200 x 200 x 16	48.7	11	9	8	6	6
200 x 200 x 18	54.4	10	8	7	6	6
200 x 200 x 20	60.1	9	7	6	5	5
200 x 200 x 26	76.8	7	6	5	4	4

Universal Beams	kg/m	6.0-9.0 m	9.1-10.5 m	10.6-12.0 m	12.1-13.5 m	13.6-15.0 m	15.1-16.5 m	16.6-18.0 m	20.0 m
150 UB	14.0	36	30	24	24	20	20	16	
	18.0	30	24	20	18	16	16	14	
180 UB	16.1	30	24	20	18	16	16	14	
	18.1	30	24	20	18	16	16	14	
	22.2	24	20	16	16	14	12	12	

Continued on next page...

Hot Rolled Structural Standard Bundle Configuration

Universal Beams	kg/m	6.0-9.0 m	9.1-10.5 m	10.6-12.0 m	12.1-13.5 m	13.6-15.0 m	15.1-16.5 m	16.6-18.0 m	20.0 m
200 UB	18.2	30	24	22	18	18	16	14	
	22.3	18	18	18	16	14	12	12	
	25.4	18	18	16	14	12	10	10	
	29.8	18	16	12	12	10	10	8	
250 UB	25.7	20	18	16	14	12	10	10	
	31.4	16	14	12	10	10	8	8	
	37.3	14	12	10	8	8	8	7	
310 UB	32.0	16	14	12	10	10	8	8	
	40.4	12	10	10	8	8	6	6	6
	46.2	12	10	8	8	7	6	6	5
360 UB	44.7	12	10	7	7	7	6	6	5
	50.7	10	7	7	7	6	5	5	4
	56.7	7	7	7	6	5	5	4	4
410 UB	53.7	10	7	6	6	6	5	5	4
	59.7	7	7	6	6	5	5	4	4
460 UB	67.1	6	6	6	5	4	4	4	3
	74.6	6	6	5	4	4	4	3	3
	82.1	6	5	5	4	4	3	3	3
530 UB	82.0	5	5	5	4	4	3	3	3
	92.4	5	5	4	4	3	3	3	1
610 UB	101	4	4	3	3	3	3	1	1
	113	4	4	3	3	1	1	1	1
	125	4	3	3	1	1	1	1	1

Universal Columns	kg/m	6.0-9.0 m	9.1-10.5 m	10.6-12.0 m	12.1-13.5 m	13.6-15.0 m	15.1-16.5 m	16.6-18.0 m	20.0 m
100 UC	14.8	36	28	24	24	21	18	16	
150 UC	23.4	21	18	15	15	12	12	10	
	30.0	18	15	12	12	10	10	8	
	37.2	12	12	10	8	8	8	6	
200 UC	46.2	12	10	8	8	6	6	6	
	52.2	10	8	6	6	6	5	5	
	59.5	8	8	6	6	5	5	4	
250 UC	72.9	6	6	4	4	4	4	3	3
	89.5	6	4	4	4	3	3	3	2
310 UC	96.8	3	3	3	3	3	3	2	2
	118	3	3	3	3	2	2	2	
	137	3	3	3	2	2	2	2	
	158	3	2	2	2	2	1	1	

Not all lengths available at all locations

Plate - Grade 250



Thickness mm	Mass kg/m ²	Width mm	Length m	kg/lineal metre of plate width	Thickness mm	Mass kg/m ²	Width mm	Length m	kg/lineal metre of plate width		
5	39.25	2400	9.0	94.20	36	282.60	2400	6.0	678.24		
		3000	9.0	117.75			2400	9.0	678.24		
6	47.10	2400	6.0	113.04	40	314.00	1800	6.0	565.20		
		2400	9.0	113.04			2400	6.0	753.60		
		3000	9.0	141.30			2400	9.0	753.60		
		3200	12	150.72			45	353.25	2400	6.0	847.80
		1800	6.0	113.04					2400	9.0	847.80
8	62.80	2400	6.0	150.72	50	392.50	1800	6.0	706.50		
		2400	9.0	150.72			2400	6.0	942.00		
		3000	9.0	188.40			2400	9.0	942.00		
		3200	12	200.96			55	431.75	2400	6.0	1036.20
		1800	6.0	141.30					2400	8.4	1036.20
10	78.50	2400	6.0	188.40	60	471.00	1800	6.0	847.80		
		2400	9.0	188.40			2400	6.4	1130.40		
		3000	9.0	235.50			70	549.50	1800	6.0	989.10
		3200	12	251.20					2400	6.0	1318.80
		12	94.20	1800			6.0	169.56	80	628.00	1800
2400	6.0			226.08	2400	6.0	1507.20				
2400	9.0			226.08	90	706.50	1800	6.0			1695.60
3000	6.0			282.60			100	785.00			1800
16	125.60			3000	9.0	282.60	110	863.50			2400
		3200	12	301.44	1800	5.0			1554.30		
		1800	6.0	226.08	2400	4.0			2072.40		
		2400	6.0	301.44	120	942.00			1800	4.6	1695.60
		2400	9.0	301.44					2400	3.1	2260.80
20	157.00	3000	6.0	376.80	130	1021.0	1800	4.2	1837.80		
		3000	9.0	376.80			2400	3.1	2450.40		
		3200	12	401.92			140	1099.0	1800	3.9	1978.20
		1800	6.0	282.60					2400	2.9	2637.60
		25	196.25	2400			6.0	376.80	150	1177.5	1800
2400	9.0			376.80	2400	2.7	2826.00				
3000	9.0			471.00	28	279.80	1800	6.0			527.52
3200	12			502.40			2400	9.0			527.52
1800	6.0			353.25							
28	279.80	2400	6.0	471.00							
		2400	9.0	471.00							
		3000	9.0	588.75							
		3200	12	628.00							

Plate - Grade 350

Thickness mm	Mass kg/m ²	Width mm	Length m	kg/lineal metre of plate width
5	39.25	2400	9.0	94.20
		3000	9.0	117.75
6	47.10	2400	9.6	113.04
8	62.80	2400	9.6	150.72
10	78.50	2400	9.6	188.40
		3100	9.6	243.35
12	94.20	2400	9.6	226.08
		3100	9.6	292.02
16	125.60	2400	9.6	301.44
		3100	9.6	389.36
20	157.00	2400	9.6	376.80
		3100	9.6	486.70
25	196.25	2400	9.6	471.00
32	251.20	2400	9.6	602.88
40	314.00	2400	7.6	753.60
50	392.50	2400	7.6	942.00
60	471.00	2400	7.6	1130.40
70	549.50	2400	6.0	1318.80
80	628.00	2400	5.5	1507.20

Plate - Grade K1042

Thickness mm	Mass kg/m ²	Width mm	Length m	kg/lineal metre of plate width
12	94.20	2400	6.0	226.08
16	125.60	2400	6.2	301.44
20	157.00	2400	6.0	376.80
25	196.25	2400	6.0	471.00
32	251.20	2400	6.3	602.88
40	314.00	2400	7.6	753.60
50	392.50	2400	6.0	942.00
60	471.00	2400	6.0	1130.40
70	549.50	2400	5.8	1318.80
80	628.00	2400	5.0	1507.20

Plate - Boiler (AS 1548-PT 460 NR)

Thickness mm	Mass kg/m ²	Width mm	Length m	kg/lineal metre of plate width
6	47.10	3100	9.6	146.01
8	62.80	3100	9.6	194.68
10	78.50	3100	9.6	243.35
12	94.20	3100	9.6	292.02
16	125.60	3100	9.6	389.36
20	157.00	3100	9.6	486.70
25	196.25	3100	9.6	608.38
32	251.20	3100	9.6	778.72
40	314.00	2400	9.6	753.60
50	392.50	2400	7.6	942.00
60	471.00	2400	6.0	1130.40
70	549.50	2400	6.0	1318.80
80	628.00	2400	5.2	1507.20
90	706.50	2400	5.2	1695.60
100	785.00	2400	5.2	1884.00

Plate - Pressure Vessel (SA/AS 1548-7-430R)

Thickness mm	Mass kg/m ²	Width mm	Length m	kg/lineal metre of plate width
5	39.25	2400	9.0	94.20

Plate - Lasercut™ (AS/NZS 3678-Lasercut™250)

Thickness mm	Mass kg/m ²	Width mm	Length m	kg/lineal metre of plate width
16	125.60	1500	6.0	188.40
		1500	9.0	188.40
		2400	6.0	301.44
20	157.00	1500	6.0	235.50
		1500	9.0	235.50
		2400	6.0	376.80
25	196.25	1500	6.0	294.38
		1500	9.0	294.38
		2400	6.0	471.00
32	251.20	1500	6.0	376.80
		1500	9.0	376.80

Plate - Coil (AS/NZS 1594 - HA250)



Thickness mm	Mass kg/m ²	Width mm	
		910 - 1550	1765 - 1800
3	23.55	Typically 1200mm wide coils are stored.	Typically 1800mm
4	31.40		wide coil stored.
5	39.25	Also 1500mm may	These coils are supplied as mill widths.
6	47.10	be stored	
8	62.80	These coils supplied as mill widths.	n/a
10	78.50		n/a
12	94.20		n/a

Plate - Coil Floor (AS/NZS 1594 - HA250)



Thickness mm	Mass kg/m ²	Width mm	kg/lineal metre of plate width
2.1*	18.54	1200	22.24
3.0	25.55	1200	30.66
5.0	41.25	1200	49.50
6.0	49.10	1500	61.88
		1200	58.92
		1500	73.65
8.0	64.80	1800	88.38
		1500	97.20

* 2.1mm Thickness Floorplate is considered 1210mm in width. The above sizes of floor plate coils may weigh approximately 14 tonnes each

Plate - Floor (AS/NZS 3678 - 250)



Thickness mm	Mass kg/m ²	Width mm	Length m	kg/lineal metre of plate width
6	49.10	1800	6.0	88.38
8	64.80	1800	6.0	116.64
10	80.50	1800	6.0	144.90
12	96.20	1800	6.0	173.16

Plate - Quenched & Tempered



Thickness mm	Mass kg/m ²	Bisalloy 80	Bisalloy 400	Bisalloy 500
		Tensile Strength: Typical - 830MPa	Tensile Strength: Typical - 1320MPa	Tensile Strength: Typical - 1640MPa
5	39.25	1525 x 8000	2485 x 8000	
6	47.10	1525 x 8000 2485 x 8000	2485 x 8000	
8	62.80	2485 x 8000	2485 x 8000	
10	78.50	2485 x 8000 3100 x 8000	2485 x 8000	
12	94.20	2485 x 8000	2485 x 8000	2485 x 8000
16	125.60		2485 x 8000	2485 x 8000
20	157.00		2485 x 8000	2485 x 8000
25	196.25		2485 x 8000	2485 x 8000
32	251.20		2485 x 8000	2485 x 8000
40	314.00		2485 x 8000	2485 x 8000
50	392.50		2485 x 8000	
60	471.00		2485 x 8000	

Steel Plates

Structural Plate - International Standard Comparisons

Structural Plate - International Standards							
Tensile Strength MPa	Australian AS 3678	European* EN10025	British* BS 4360	German* DIN17100	Japanese JIS	American ASTM	International ISO 630
290				St33			
300	200						
310						A283A	Fe310-0
330					G3101-SS330		
360		S235JR	40A, B, C, D	St37-2 St37-3		A283B	Fe360A B, C, D
380						A283C	
400					G3101-SS400 G316-SM400 A, B, C	A36, A573-400	
410	250 250L15	S275JR S275JO S275 J2G3 S275 J2G4			St44-2 St44-3	A283D A284C, D A529 A572-290	
430	300 300L15	Fe430B C, D1, D2	43A, B, C, D			A633A	Fe430A B, C, D
450	350 350L15					A573-450 A572-345	
480	400 400L15					A573-485	
490		S355JR S355JD S355 J2G3	50A, B, C, D	S152-3	G3101-SS490 G3106-SM490 A, B, C G3106-SM490 YA, YB		Fe510 B, C, D
520	450 450L15				G3106-SM520 B, C	A572-415	Fe510 B, C, D
540					G3101-SS540		

* EN10025 has replaced BS4360 and DIN17100 Standards

- The table indicates the approximate relationship between Australian grades and their international counterparts.
- Grades are shown in increasing tensile strength order. In the case of American ASTM Standards some grades are shown in increasing yield strength (YS) order, as their position in the hierarchy is different when based on the yield strength compared to tensile strength (TS).
- For grades with suffix letters C, D on British, European and International Standards, B, C on Japanese Standards and suffix numbers 2, 3 on German Standards, the appropriate Australian alternative is the nearest L15 grade of the equivalent strength level (ie. High or Medium).
- This table is designed for customers to determine the nearest available Australian grade to an international specification.

Boiler Plate - International Standard Comparisons

Boiler Plate - International Standards

Tensile Strength MPa	Australian AS 3678	European* EN10025	British* BS 4360	German* DIN17100	Japanese JIS	American ASTM	International ISO 630
310						A285-A	
340						A285-B	
360		2-P235GH	151-360 161-360 164-360	H1			P235
380						A285-C A442-55 A515-55 A516-55	
390		3-P275N					
400			151-400 161-400 164-400 224-400	H11	G3103-SB410 G3115-SPV235 G3118-SGV410 G3126-SLA235	A682-A	P265
410		2P265GH			G3118-SGV410		P265
415						A515-65 A518-60	
430	7-430						
440					G3126-SLA325		
450					G3118-SB450 G3118-SGC450	A515-65 A516-65	
460	7-460	2-P295GH				A662-B*	P290
480					G3103-SB480 G3118-SGV480		
490	7-490		224-490	19Mn6	G3115-SPV3115	A515-70 A516-70 A841	P315
490	5-490	3-P355GH			G3126-SLA360	A537-C11 A737-B A841	P315
510		2-P355GH					P355
520					G3115-SPV355	A299 A455 A738-A	

* EN10025 has replaced BS4360 and DIN17100 Standards

- The table indicates the approximate relationship between Australian grades and their international counterparts.
- Grades are shown in increasing tensile strength order. AS 1548-5-490 & equivalent grades have a higher minimum yield strength requirement than the corresponding AS1548-7-490 & equivalent grades.
- Grade equivalence shown is based on room temperature tensile properties only.

Nominal Size (NB)	Section	Outside Diameter mm	Wall Thickness mm	Mass kg/m	Metres per Tonne	Pack Size (Lns)
15	Medium	21.3	2.6	1.21	830	217
20	Extra Light	26.9	2.0	1.23	814	127
	Light		2.3	1.40	717	127
	Medium		2.6	1.56	642	127
	Heavy		3.2	1.87	535	127
	Extra Heavy		4.0	2.26	443	127
25	Extra Light	33.7	2.0	1.56	640	91
	Light		2.6	1.99	501	91
	Medium		3.2	2.41	414	91
	Heavy		4.0	2.94	340	91
32	Extra Light	42.4	2.0	1.99	502	61
	Light		2.6	2.55	392	61
	Medium		3.2	3.10	322	61
	Heavy		4.0	3.80	263	61
40	Extra Light	48.3	2.3	2.61	382	61
	Light		2.9	3.25	308	61
	Medium		3.2	3.57	280	61
	Heavy		4.0	4.38	228	61
	Extra Heavy		5.4	5.71	175	61
50	Extra Light	60.3	2.3	3.29	304	37
	Light		2.9	4.11	244	37
	Medium		3.6	5.03	199	37
	Heavy		4.5	6.19	161	37
	Extra Heavy		5.4	7.31	137	37
65	Extra Light	76.1	2.3	4.19	239	37
	Light		3.2	5.75	174	37
	Medium		3.6	6.43	156	37
	Heavy		4.5	7.93	126	37
	Extra Heavy		5.9	10.2	97.9	37
80	Extra Light	88.9	2.6	5.53	181	19
	Light		3.2	6.76	148	19
	Medium		4.0	8.37	120	19
	Heavy		5.0	10.3	96.8	19
	Extra Heavy		5.9	12.1	82.8	19
90	Extra Light	101.6	2.6	6.35	158	19
	Light		3.2	7.77	129	19
	Medium		4.0	9.63	104	19
	Heavy		5.0	11.9	84.0	19

End Finish: Plain ends, shouldered, roll grooved, screwed BSP or swaged

Continued on next page...

Pipe - Painted (AS/NZS 1163-2009)

6.5m

Nominal Size (NB)	Section	Outside Diameter mm	Wall Thickness mm	Mass kg/m	Metres per Tonne	Pack Size (Lns)
100	Extra Light	114.3	3.2	8.77	114	19
	Light		3.6	9.83	102	19
	Medium		4.5	12.2	82.2	19
	Heavy		5.4	14.5	69.1	19
125	Extra Light	139.7	3.0	10.1	98.9	13
	Light		3.5	11.8	85.1	13
	Medium		5.0	16.6	60.2	13
	Heavy		5.4	17.9	55.9	13
150	Extra Light	165.1	3.0	12.0	83.4	10
	Light		3.5	13.9	71.7	10
	Medium		5.0	19.7	50.7	10
	Heavy		5.4	21.3	47.0	10

End Finish: Plain ends, shouldered, roll grooved, screwed BSP or swaged

OZTUBE™ Pipe - Painted (AS 1450)

6.5m

Nominal Size (NB)	Section	Outside Diameter mm	Wall Thickness mm	Mass kg/m	Metres per Tonne	Pack Size 6.5 (Lns)
20	Extra Light	26.9	2.0	1.23	814	127
	Light		2.3	1.40	717	127
	Medium		2.6	1.56	642	127
25	Extra Light	33.7	2.0	1.56	640	91
	Light		2.6	1.99	501	91
	Medium		3.2	2.41	414	91
32	Light	42.4	2.6	2.55	392	61
	Medium		3.2	3.10	322	61
40	Light	48.3	2.9	3.25	308	61
	Medium		3.2	3.57	280	61
50	Extra Light	60.3	2.3	3.29	304	37
	Light		2.9	4.11	244	37
	Medium		3.6	5.03	199	37
65	Extra Light	76.1	2.3	4.19	239	37
	Medium		3.6	6.43	156	37

End Finish: Plain ends

Nominal Size (NB)	Section	Outside Diameter mm	Wall Thickness mm	Mass kg/m	Metres per Tonne	Pack Size (Lns)
15	Medium	21.3	2.6	1.24	806	217
20	Extra Light	26.9	2.0	1.28	784	127
	Light		2.3	1.44	694	127
	Medium		2.6	1.60	623	127
	Heavy		3.2	1.92	522	127
25	Extra Light	33.7	2.0	1.62	616	91
	Light		2.6	2.05	487	91
	Medium		3.2	2.47	404	91
	Heavy		4.0	3.00	334	91
32	Extra Light	42.4	2.0	2.07	483	61
	Light		2.6	2.63	381	61
	Medium		3.2	3.18	315	61
	Heavy		4.0	3.87	258	61
40	Extra Light	48.3	2.3	2.70	369	61
	Light		2.9	3.33	300	61
	Medium		3.2	3.65	274	61
	Heavy		4.0	4.46	224	61
50	Extra Light	60.3	2.3	3.40	294	37
	Light		2.9	4.21	237	37
	Medium		3.6	5.14	195	37
	Heavy		4.5	6.30	159	37
65	Extra Light	76.1	2.3	4.33	231	37
	Light		3.2	5.89	170	37
	Medium		3.6	6.56	152	37
	Heavy		4.5	8.07	124	37
80	Extra Light	88.9	2.6	5.70	176	19
	Light		3.2	6.92	144	19
	Medium		4.0	8.53	117	19
	Heavy		5.0	10.5	95.3	19
90	Extra Light	101.6	2.6	6.53	153	19
	Light		3.2	7.95	126	19
	Medium		4.0	9.81	102	19
	Heavy		5.0	12.1	82.7	19
100	Extra Light	114.3	3.2	8.98	111	19
	Light		3.6	10.0	99.6	19
	Medium		4.5	12.4	80.8	19
	Heavy		5.4	14.7	68.1	19

End Finish: Plain ends, shouldered, roll grooved, screwed BSP or swaged

Continued on next page...

Pipe - Galvanised (AS/NZS 1163-2009)

6.5m



Nominal Size (NB)	Section	Outside Diameter mm	Wall Thickness mm	Mass kg/m	Metres per Tonne	Pack Size (Lns)
125	Extra Light	139.7	3.0	10.4	6.4	13
	Light		3.5	12.0	83.2	13
	Medium		5.0	16.9	59.3	13
	Heavy		5.4	18.1	55.2	13
150	Extra Light	165.1	3.0	12.3	81.3	10
	Light		3.5	14.3	70.2	10
	Medium		5.0	20.0	49.9	10
	Heavy		5.4	21.6	46.4	10

End Finish: Plain ends, shouldered, roll grooved, screwed BSP or swaged

Pipe - DuraGal® & SupaGal® Extra Light (AS/NZS 1163-2009) 6.5m



Nominal Size (NB)	Outside Diameter mm	Wall Thickness mm	Mass kg/m	Metres per Tonne	Pack Size (Lns)
20	26.9	2.0	1.23	814	127
25	33.7	2.0	1.56	640	91
32	42.4	2.0	1.99	502	61
40	48.3	2.3	2.61	383	61
50	60.3	2.3	3.29	304	37
65#	76.1	2.3	4.19	212	37

#DuraGal® only.

CHS Large Structural (AS/NZS 1163-2009 C350LO)



Size d _o x t (mm)	Mass kg/m	Pack Size (Lns)	Size d _o x t (mm)	Mass kg/m	Pack Size (Lns)	Size d _o x t (mm)	Mass kg/m	Pack Size (Lns)	
168.3 x 4.8	19.4	1	323.9 x 6.4	50.1	1	406.4 x 12.5	121	1	
x 6.4	25.6	1		73.7	1		x 12.7	123	1
x 7.1	28.2	1		x 12.5	96.0	1	457.0 x 6.4	71.1	1
				x 12.7	97.5	1		x 9.5	105
219.1 x 4.8	25.4	1	355.6 x 6.4	55.1	1	x 12.5		137	1
x 6.4	33.6	1		81.1	1	x 12.7	139	1	
x 8.2	42.6	1		x 12.5	106	1	508.0 x 6.4	79.2	1
x 12.5	63.7	1		x 12.7	107	1		x 9.5	117
273.1 x 4.8	31.8	1	406.4 x 6.4	63.1	1	x 12.5		153	1
273.1 x 6.4	42.1	1		x 9.5	93.0	1	x 12.7	155	1
x 9.3	60.5	1							
x 12.5	80.3	1							

SHS - Squares (AS/NZS 1163-2009)

Various Standard Lengths



Size mm x mm x mm	Surface Finish	Mass kg/m	Metres per Tonne	Length/ Pack		Size mm x mm x mm	Surface Finish	Mass kg/m	Metres per Tonne	Length/ Pack			
				Standard						8.0	12		
				6.5	8.0								
20 x 20	x 1.6	P,S,D	0.873	1150	96	65 x 65	x 3.0	P,S,D	5.66	177	36		
	x 2.0	P,S	1.05	953	96		x 4.0	P,S,D	7.23	138	30		
25 x 25	x 1.6	P,S,D	1.12	890	100	75 x 75	x 2.0	P,S,D	4.50	222	36		
	x 2.0	P,S,D	1.36	733	100		x 2.5	P,S,D	5.56	180	30		
	x 2.5	P,S,D	1.64	610	100		x 3.0	P,S,D	6.60	152	30		
	x 3.0	P,S,D	1.89	529	100		x 3.5	P,S,D	7.53	133	25		
30 x 30	x 1.6	P,S,D	1.38	727	100	90 x 90	x 2.0	P,D	5.45	184	20		
	x 2.0	P,S,D	1.68	596	100		x 2.5	P,D	6.74	148	20		
	x 2.5	P,S	2.03	492	100		100 x 100	x 2.0	P,D	6.07	165	20	20
	x 3.0	P,S	2.36	423	64			x 2.5	P,S,D	7.53	133	20	
35 x 35	x 1.6	P,S,D	1.63	615	100	125 x 125	x 4.0	C,P	14.8	67.7	12	9	
	x 2.0	P,S,D	1.99	502	100		x 5.0	C,P	18.2	55.0	12	9	
	x 2.5	P,S,D	2.42	412	64		x 6.0	C,P	21.4	46.6	9	6	
	x 3.0	P,S,D	2.83	353	64		x 8.0	L	27.7	36.1	6	4	
40 x 40	x 1.6	P,S,D	1.88	533	81	100 x 100	x 9.0	P,L	23.5	42.5	9	6	
	x 2.0	P,S,D	2.31	434	81		x 10.0	L	25.6	39.0	6	6	
	x 2.5	P,S,D	2.82	355	64		125 x 125	x 4.0	C,P	14.8	67.7	12	9
	x 3.0	P,S,D	3.30	303	64			x 5.0	C,P	18.2	55.0	12	9
	x 4.0	P,S,D	4.09	244	49		x 6.0	C,P	21.4	46.6	9	6	
50 x 50	x 1.6	P,S,D	2.38	420	64	100 x 100	x 8.0	L	21.4	46.7	9	6	
	x 2.0	P,S,D	2.93	300	64		x 9.0	P,L	23.5	42.5	9	6	
	x 2.5	P,S,D	3.60	278	49		x 10.0	L	25.6	39.0	6	6	
	x 3.0	P,S,D	4.25	236	49		125 x 125	x 4.0	C,P	14.8	67.7	12	9
	x 4.0	P,S,D	5.35	187	36			x 5.0	C,P	18.2	55.0	12	9
	x 5.0	P,S,D	6.39	156	30		x 6.0	C,P	21.4	46.6	9	6	
	x 6.0	L	7.32	137	25		x 8.0	L	27.7	36.1	6	4	
	65 x 65	x 1.6	P,S,D	3.13	319		49	x 9.0	C,P,L	30.6	32.7	8	4
x 2.0		P,S,D	3.88	258	42	x 10.0	L	33.4	29.9	4	4		
x 2.5		P,S,D	4.78	209	42								

SHS - Squares (AS/NZS 1163-2009)

Various Standard
Lengths



Size mm x mm x mm	Surface Finish	Mass kg/m	Metres per Tonne	Length/ Pack		Size mm x mm x mm	Surface Finish	Mass kg/m	Metres per Tonne	Length/ Pack		
				Standard						Standard		
				8.0	12					8.0	12	
150 x 150	x 5.0	C,P	22.1	45.3	9	6	300 x 300	x 8.0	L	71.6	14.0	1
	x 6.0	C,P	26.2	38.2	6	6		x 10.0	L	88.4	11.3	1
	x 8.0	L	33.9	29.5	6	4		x 12.5	L	109	9.21	1
	x 9.0	C,P,L	37.7	26.6	6	4		x 16.0	L	136	7.36	1
	x 10.0	L	41.3	24.2		2						
200 x 200	x 5.0	C,P	29.9	33.4	6	4	350 x 350	x 8.0	L	84.2	11.9	1
	x 6.0	C,P	35.6	28.1	4	4		x 10.0	L	104	9.61	1
	x 8.0	L	46.5	21.5	4	2		x 12.5	L	128	7.80	1
	x 9.0	C,L	51.8	19.3	4	2		x 16.0	L	161	6.21	1
	x 10.0	L	57.0	17.6		2	400 x 400	x 10.0	L	120	8.35	1
	x 12.5	L	69.4	14.4		2		x 12.5	L	148	6.76	1
	x 16.0	L	85.5	11.7		1		x 16.0	L	186	5.38	1
250 x 250	x 6.0	C,L	45.0	22.2	4	2						
	x 8.0	L	59.1	16.9	4	2						
	x 9.0	C,L	65.9	15.2	2	2						
	x 10.0	L	72.7	13.8		2						
	x 12.5	L	89.0	11.2		1						
	x 16.0	L	111	9.04		1						

OZTUBE™ SHS - Squares (AS 1450)

Various Standard
Lengths



Size mm x mm x mm	Surface Finish	Mass kg/m	Metres per Tonne	Length/ Pack		Size mm x mm x mm	Surface Finish	Mass kg/m	Metres per Tonne	Length/ Pack		
				Standard						Standard		
				6.5	8.0					6.5	8.0	
25 x 25	x 1.6	P, PG	1.12	890	100	50 x 50	x 1.6	P, PG	2.38	420	64	
	x 2.0	P, PG	1.36	733	100		x 2.0	P, PG	2.93	300	64	
30 x 30	x 1.6	P, PG	1.38	727			100	x 2.5	P	3.60	278	49
	x 2.0	P, PG	1.68	596			100	x 3.0	P, PG	4.25	236	49
	x 2.5	P	2.03	492			100	65 x 65	x 1.6	PG	3.13	319
40 x 40	x 1.6	P, PG	1.88	533			81		x 2.0	P, PG	3.88	258
	x 2.0	P, PG	2.31	434		81	x 2.5		P	4.78	209	42
	x 2.5	P	2.82	355		64	x 3.0		P, PG	5.66	177	36
	x 3.0	P, PG	3.30	303		64						

SHS Surface Finishes
Si - Si-Tek
C - Clear

P - Painted
PG - Pre-Gal
S - SupaGal
D - DuraGal
L - Lite Oil

RHS - Rectangles (AS/NZS 1163-2009)

Various Standard
Lengths



Size mm x mm x mm	Surface Finish	Mass kg/m	Metres per Tonne	Length/ Pack		Size mm x mm x mm	Surface Finish	Mass kg/m	Metres per Tonne	Length/ Pack	
				Standard						Standard	
				8.0	12					8.0	12
50 x 20 x 1.6 x 2.0 x 2.5 x 3.0	P,D	1.63	615	96		125 x 75 x 2.0 x 2.5 x 3.0 x 4.0 x 5.0 x 6.0	P,D	6.07	165	24	
	P,D	1.99	502	96			P,S,D	7.53	133	24	20
	P,D	2.42	412	72			P,S,D	8.96	112	20	20
	P,D	2.83	353	72			P,S,D	11.6	86.0	15	15
50 x 25 x 1.6 x 2.0 x 2.5 x 3.0	P,S,D	1.75	571	96		127 x 51 x 3.5 x 5.0 x 6.0	P,D	14.2	70.2	15	12
	P,S,D	2.15	465	96			P,D	16.7	59.7	12	6
	P,S,D	2.62	382	72			P	9.07	110	21	
	P,S,D	3.07	326	60			P	12.5	79.9	18	
65 x 35 x 2.0 x 2.5 x 3.0 x 4.0	P,S,D	2.93	341	54		150 x 50 x 2.0 x 2.5 x 3.0 x 4.0 x 5.0 x 6.0	P	14.7	68.2	14	
	P,S,D	3.60	278	54			P,D	6.07	165	21	21
	P,S,D	4.25	236	45			P,D	7.53	133	24	
	P,D	5.35	187	45			P,S,D	8.96	112	21	15
75 x 25 x 1.6 x 2.0 x 2.5	P,S,D	2.38	420	65		150 x 50 x 4.0 x 5.0 x 6.0	P,S,D	11.6	86.0	15	15
	P,S,D	2.93	341	65			P,S,D	14.2	70.2	15	9
	P,S,D	3.60	278	48			C,P,D	16.7	59.7	15	9
75 x 50 x 1.6 x 2.0 x 2.5 x 3.0 x 4.0 x 5.0 x 6.0	P,S,D	3.01	332	54	54	150 x 100 x 4.0 x 5.0 x 6.0 x 8.0 x 9.0 x 10.0	P	14.8	67.7	12	9
	P,S,D	3.72	269	42	42		P	18.2	55.0	12	8
	P,S,D	4.58	218	42			P	21.4	46.6	9	6
	P,S,D	5.42	184	35	24		P	27.7	36.1	6	4
	P,S,D	6.92	145	28	24		P	30.6	32.7	6	4
	P,S,D	8.35	120	24			P,L	33.4	29.9		4
76 x 38 x 2.5 x 3.0 x 4.0	P	4.15	241	45		152 x 76 x 5.0 x 6.0	P,L	16.4	60.7	12	12
	P	4.90	204	40			P,L	19.4	51.5	9	9
	P	6.23	161	32							
100 x 50 x 1.6 x 2.0 x 2.5 x 3.0 x 3.5 x 4.0 x 5.0 x 6.0	P,D	3.64	275	32	32	200 x 100 x 4.0 x 5.0 x 6.0 x 8.0 x 9.0 x 10.0	P	17.9	55.8	8	6
	P,S,D	4.50	222	32	32		P	22.1	45.3	8	6
	P,S,D	5.56	180	32	24		P	26.2	38.2	8	4
	P,S,D	6.60	152	32	24		P,L	33.9	29.5	6	4
	P,S,D	7.53	133	24	18		P	37.7	26.6	6	4
	P,S,D	8.49	118	24	18		P,L	41.3	24.2		2
102 x 76 x 3.5 x 5.0 x 6.0	P,S,D	10.3	96.9	18	15	250 x 150 x 5.0 x 6.0 x 8.0 x 9.0 x 10.0 x 12.5 x 16.0	C	29.9	33.4	6	4
	P,S,D	12.0	83.1	15	12		C	35.6	28.1	4	4
	P	9.07	110	20			C,L	46.5	21.5	4	2
	P	12.5	79.9	16			C,L	51.8	19.3	4	2
	P	14.7	68.2	12			L	57.0	17.6		2
							L	69.4	14.4		2

Continued on next page...

RHS - Rectangles (AS/NZS 1163-2009)

Various Standard
Lengths



Size mm x mm x mm	Surface Finish	Mass kg/m	Metres per Tonne	Length/ Pack	
				Standard	
				8.0	12
300 x 200	x 6.0	L	45.0	22.2	2
	x 8.0	C,P,L	59.1	16.9	2
	x 10.0	C,P,L	72.7	13.8	2
	x 12.5	L	89.0	11.2	1
	x 16.0	L	111	9.04	1
350 x 250	x 6.0	L	54.4	18.4	2
	x 8.0	L	71.6	14.0	2
	x 10.0	L	88.4	11.3	1
	x 12.5	L	109	9.21	1
	x 16.0	L	136	7.36	1

Size mm x mm x mm	Surface Finish	Mass kg/m	Metres per Tonne	Length/ Pack	
				Standard	
				8.0	12
400 x 200	x 8.0	L	71.6	14.0	2
	x 10.0	L	88.4	11.3	1
	x 12.5	L	109	9.21	1
	x 16.0	L	136	7.36	1
400 x 300	x 8.0	L	84.2	11.9	1
	x 10.0	L	104	9.61	1
	x 12.5	L	128	7.80	1
	x 16.0	L	161	6.21	1

OZTUBE™ RHS - Rectangles (AS 1450)

8m



Size mm x mm x mm	Surface Finish	Mass kg/m	Metres per Tonne	Length/ Pack	
				Standard	
				6.5	8
50 x 25	x 1.6	P, PG	1.75	571	96
	x 2.0	P, PG	2.15	465	96
	x 2.5	P, PG	2.62	382	72
	x 3.0	P	3.07	326	72
65 x 35	x 2.0	P	2.93	341	54
	x 2.5	P	3.60	278	54
	x 3.0	P	4.25	236	45

Size mm x mm x mm	Surface Finish	Mass kg/m	Metres per Tonne	Length/ Pack	
				Standard	
				6.5	8
75 x 25	x 1.6	P	2.38	420	65
	x 2.0	P	2.93	341	65
	x 2.5	P	3.60	278	48
75 x 50	x 1.6	P	3.01	332	54
	x 2.0	P, PG	3.72	269	42
	x 2.5	P	4.58	218	42
	x 3.0	P, PG	5.42	184	35

Tubecolor® (TS50)

Various Lengths

Size mm x mm	Thickness mm	Mass kg/m	Metres per Tonne
76 x 38	1.20	2.29	437
	1.60	3.00	333
90 x 38	2.00	3.68	272
	2.00	4.16	240

Size mm x mm	Thickness mm	Mass kg/m	Metres per Tonne
90 x 90	2.00	6.02	166
100 x 50	2.00	5.15	194
150 x 50	2.00	6.66	150

Note: Tubecolor® is only readily available in WA

RHS Surface Finishes Si - Si-Tek P - Painted S - SupaGal® L - Lite Oil
C - Clear PG - Pre-Gal D - DuraGal®



Size (OD) mm	Thickness mm	Mass kg/m	Metres per Tonne	Lengths per Pack	Size (OD) mm	Thickness mm	Mass kg/m	Metres per Tonne	Lengths per Pack		
16.0	1.2	0.438	2280	217	40.0	1.6	1.52	660	91		
	1.6	0.568	1760	217		41.3	1.2	1.19	843	91	
19.0	0.9	0.402	2490	217	41.3		1.6	1.57	638	91	
	1.2	0.527	1900	217		2.0	1.94	516	91		
	1.4	0.608	1650	217		2.6	2.48	403	91		
	1.6	0.687	1460	217		3.2	3.01	333	91		
	2.0	0.838	1190	217		44.5	0.9	0.968	1030	91	
	22.2	0.9	0.473	2120			217	1.2	1.28	780	91
1.2		0.621	1610	217	1.4		1.49	672	91		
1.4		0.718	1390	217	1.6		1.69	591	91		
1.6		0.813	1230	217	2.0		2.10	477	91		
2.0		0.996	1000	217	2.6		2.69	372	91		
2.6		1.26	796	217	3.2	3.26	307	91			
25.4	0.9	0.544	1840	169	47.6	0.9	1.04	965	61		
	1.2	0.716	1400	169		1.2	1.37	728	61		
	1.4	0.829	1210	169		1.4	1.60	625	61		
	1.6	0.939	1060	169		1.6	1.82	551	61		
	2.0	1.15	866	169		2.0	2.25	445	61		
	2.6	1.46	684	169		2.6	2.89	347	61		
	3.2	1.75	571	169		3.2	3.50	285	61		
	31.8	0.9	0.686	1460		127	50.8/ 51.0	1.2	1.47	679	61
1.2		0.906	1100	127	1.4	1.71		584	61		
1.4		1.05	953	127	1.6	1.94		515	61		
1.6		1.19	839	127	2.0	2.41		414	61		
2.0		1.47	680	127	2.3	2.75		363	61		
3.2		2.26	443	127	2.5	2.98		335	61		
35.0		1.2	1.00	1000	91	54.0		2.6	3.09	323	61
		1.6	1.32	759	91			3.2	3.76	265	61
	2.0	1.63	614	91	1.2		1.56	640	61		
	2.6	2.08	481	91	1.4		1.82	551	61		
	3.2	2.51	398	91	1.6		2.07	484	61		
	38.0	0.9	0.823	1210	91		2.0	2.56	390	61	
1.2		1.09	918	91	2.6	3.30	303	61			
1.6		1.44	696	91	3.2	4.01	249	61			
2.0		1.78	563	91							
2.6		2.27	441	91							
3.2		2.75	364	91							

Continued on next page...

Please note: Not all sizes are available in every finish & minimum order quantities may apply

Finishes: Hot rolled, EZYFORM®, HI-FORM®, GALVATUBE®

ERW Steel Tube - Circular

6.1m



Size (OD) mm	Thickness mm	Mass kg/m	Metres per Tonne	Lengths per Pack	Size (OD) mm	Thickness mm	Mass kg/m	Metres per Tonne	Lengths per Pack
57.2	1.2	1.66	603	61	76.2	1.2	2.22	451	37
	1.4	1.93	519	61		1.4	2.58	387	37
	1.6	2.19	456	61		1.6	2.94	340	37
	2.0	2.72	367	61		2.0	3.66	273	37
	2.6	3.50	286	61		2.6	4.72	212	37
	3.2	4.26	235	61		3.2	5.76	174	37
60.3	2.6	3.70	270	61	88.9	1.2	2.60	385	19
63.5	1.2	1.84	542	37		1.4	3.02	331	19
	1.4	2.14	466	37	1.6	3.44	290	19	
	1.6	2.44	409	37	2.0	4.29	233	19	
	2.0	3.03	330	37	2.6	5.53	181	19	
	2.6	3.90	256	37	3.2	6.76	148	19	
	3.2	4.76	210	37	100.0	1.6	3.88	257	19
69.9	2.0	3.35	298	37		101.6	1.6	3.95	253
	70.0	1.6	2.70	370	37		2.0	4.91	204
2.6		3.90	256	37	2.6		6.35	158	19
					3.2		7.77	129	19

ERW Steel Tube - Oval

6.1m



Dimensions mm x mm	Thickness mm	Mass kg/m	Metres per Tonne	Lengths per Pack	Dimensions mm x mm	Thickness mm	Mass kg/m	Metres per Tonne	Lengths per Pack
31.8 x 16.0*	1.2	0.736	1359	162	50.8 x 15.9*	1.2	1.09	915	102
	1.6	0.965	1036	162		1.6	1.44	694	102
	2.0	1.18	847	162		2.0	1.78	562	102

*Flat sided oval

Please note: Not all sizes are available in every finish & minimum order quantities may apply

Finishes: Hot rolled, EZYFORM®, HI-FORM®, GALVATUBE®

Dimensions mm x mm	Thickness mm	Mass kg/m	Metres per Tonne	Lengths per Pack	Dimensions mm x mm	Thickness mm	Mass kg/m	Metres per Tonne	Lengths per Pack
19.0 x 19.0	0.9	0.487	2050	168	31.8 x 31.8	1.2	1.13	885	128
	1.2	0.640	1560	168		1.4	1.31	762	128
	1.4	0.740	1350	168		1.6	1.49	671	128
	1.6	0.838	1190	168		2.0	1.84	542	128
	2.0	1.03	974	168		35.0 x 35.0	1.6	1.64	609
22.2 x 22.2	0.9	0.583	1710	168	2.0		1.99	502	84
	1.2	0.769	1300	168	2.3		2.29	4.36	84
	1.4	0.890	1120	168	38.0 x 38.0	1.2	1.37	729	84
	1.6	1.01	991	168		1.4	1.59	627	84
	2.0	1.24	805	168		1.6	1.81	551	84
25.4 x 25.4	0.9	0.668	1497	168	2.0	2.25	445	84	
	1.2	0.881	1130	168	2.5	2.78	359	84	
	1.4	1.02	979	168	50.0 x 50.0	1.6	2.39	418	60
	1.6	1.16	863	168		2.0 [#]	2.97	336	60
	2.0	1.43	700	168		60.0 x 60.0	1.6	2.89	346
30.0 x 30.0	1.2	1.05	956	128	2.0		3.59	279	32
	1.6 [#]	1.38	725	128					

Please note: Not all sizes are available in every finish & minimum order quantities may apply

Finishes: Hot rolled, EZYFORM®, HI-FORM®, GALVATUBE®

GALVATUBE® finish only

Dimensions mm x mm	Thickness mm	Mass kg/m	Metres per Tonne	Lengths per Pack	Dimensions mm x mm	Thickness mm	Mass kg/m	Metres per Tonne	Lengths per Pack	
25.4 x 12.7	0.9	0.488	2050	180	50.0 x 20.0	1.6	1.63	613	110	
	1.2	0.642	1560	180		50.0 x 25.0	1.2	1.32	757	110
	1.4	0.742	1350	180			1.4	1.53	652	110
	1.6	0.840	1190	180			1.6	1.75	573	110
31.8 x 12.7	1.2	0.762	1310	162	2.0		2.16	463	110	
	1.4	0.883	1130	162	50.8 x 31.8		1.2	1.47	679	54
	1.6	1.00	999	162			1.4	1.71	584	54
31.8 x 22.2	1.2	0.941	1060	126		1.6	1.95	513	54	
	1.4	1.09	916	126	2.0	2.42	413	54		
	1.6	1.23	813	126	57.0 x 35.0	1.6	2.19	456	72	
35.0 x 19.0	1.2	0.950	1050	144		2.0	2.72	367	72	
	1.4	1.10	908	144	70.0 x 34.0	1.6	2.44	410	42	
	1.6	1.25	800	144		2.0	3.03	330	42	
	2.0	1.54	648	144	70.0 x 50.0 [#]	1.6	2.90	345	42	
38.1 x 25.4	1.2	1.13	881	80		2.0	3.60	278	42	
	1.4	1.32	759	80	80.0 x 40.0	1.6	2.89	346	42	
	1.6	1.50	668	80		2.0	3.59	279	42	
	2.0	1.85	540	80	90.0 x 38.0 ⁺	1.6	2.89	346	42	
50.0 x 10.0 [#]	0.9	0.81	1240	125		2.0	3.84	260	42	

Please note: Not all sizes are available in every finish & minimum order quantities may apply

Finishes: Hot rolled, EZYFORM®, HI-FORM®, GALVATUBE®

GALVATUBE® finish only + Only readily available in WA

Sheet - BLACKFORM®

Base Metal Thickness mm	Width mm	kg/m ²	Base Metal Thickness mm	Width mm	kg/m ²	Base Metal Thickness mm	Width mm	kg/m ²
1.50	1200	11.77	1.95	1210	15.30	2.95	1500	23.16
1.50	1210	11.77	2.40	1200	18.84	2.95	1800	23.16
1.60	910	12.56	2.50	1195	19.63	3.00	895	23.55
1.60	1195	12.56	2.50	1210	19.63	3.00	1195	23.55
1.60	1200	12.56	2.50	1495	19.63	3.00	1210	23.55
1.60	1210	12.56	2.50	1510	19.63	3.00	1495	23.55
1.95	900	15.30	2.90	1210	22.77	3.00	1510	23.55
1.95	1195	15.30	2.90	1500	22.77	3.00	1800	23.55
1.95	1200	15.30	2.95	1200	23.16			

Sheet - BRIGHTFORM®

Base Metal Thickness mm	Width mm	kg/m ²
1.60	910	12.56
1.60	1210	12.56
1.60	1510	12.56
2.00	910	15.70

Base Metal Thickness mm	Width mm	kg/m ²
2.00	1210	15.70
2.00	1510	15.70
2.50	1210	19.63

Base Metal Thickness mm	Width mm	kg/m ²
2.95	1210	23.16
3.00	910	23.55
3.00	1210	23.55

Sheet - Hot Rolled Pickled HA3-P LY-TEN®

Base Metal Thickness mm	Width mm	kg/m ²
1.60	1210	12.56
2.00	910	15.70
2.00	1210	15.70

Base Metal Thickness mm	Width mm	kg/m ²
2.50	1210	19.63
3.00	1210	23.55
4.00	1210	31.40

Base Metal Thickness mm	Width mm	kg/m ²
5.00	1210	39.25
6.00	1210	47.10

Sheet - COLD ROLLED (CA25-E)

Base Metal Thickness mm	Width mm	kg/m ²
0.75	915	5.89
0.75	1220	5.89
0.80	1220	6.28
0.90	1220	7.07

Base Metal Thickness mm	Width mm	kg/m ²
0.95	1220	7.46
1.15	915	9.03
1.15	1220	9.03
1.55	1220	12.17

Base Metal Thickness mm	Width mm	kg/m ²
1.95	1220	15.31
2.45	1220	19.23
3.00	1220	23.55

Sheet - COLD ROLLED (CA3SN-G)

Base Metal Thickness mm	Width mm	kg/m ²
0.60	1220	4.71
0.80	1220	6.28
1.00	1220	7.85

Base Metal Thickness mm	Width mm	kg/m ²
1.20	1220	9.42
1.50	1220	11.78
1.60	1220	12.56

Base Metal Thickness mm	Width mm	kg/m ²
2.00	1220	15.70
2.50	1220	19.63
3.00	1220	23.55

Sheet - GALVABOND® (G2 Z275)

Base Metal Thickness mm	Width mm	kg/m ²	Base Metal Thickness mm	Width mm	kg/m ²	Base Metal Thickness mm	Width mm	kg/m ²
0.40	915	3.43	0.80	1525	6.57	1.20	1525	9.71
0.40	1220	3.43	0.90	915	7.36	1.50	915	12.07
0.45	915	3.82	0.90	1220	7.36	1.50	1220	12.07
0.50	1220	4.22	0.95	1200	7.75	1.50	1500	12.07
0.55	915	4.61	0.95	1220	7.75	1.55	1200	12.46
0.55	1200	4.61	0.95	1500	7.75	1.55	1220	12.46
0.55	1220	4.61	1.00	1220	8.14	1.55	1500	12.46
0.55	1500	4.61	1.00	1525	8.14	1.60	1525	12.85
0.60	1525	5.00	1.10	915	8.92	1.90	1220	15.21
0.70	1220	5.79	1.10	1220	8.92	1.95	1200	15.59
0.75	915	6.18	1.15	915	9.32	1.95	1220	15.59
0.75	1200	6.18	1.15	1200	9.32	2.40	1220	19.13
0.75	1220	6.18	1.15	1220	9.32	2.45	1200	19.52
0.75	1500	6.18	1.15	1500	9.32	2.90	1220	23.06

Sheet - GALVASKIN® (G2 Z200)

Base Metal Thickness mm	Width mm	kg/m ²	Base Metal Thickness mm	Width mm	kg/m ²	Base Metal Thickness mm	Width mm	kg/m ²
0.40	915	3.36	0.60	1525	4.93	0.90	915	7.29
0.40	1220	3.36	0.70	1220	5.72	0.90	1220	7.29
0.45	915	3.75	0.75	915	6.11	0.95	1200	7.68
0.50	1220	4.15	0.75	1200	6.11	0.95	1220	7.68
0.55	915	4.54	0.75	1220	6.11	0.95	1500	7.68
0.55	1200	4.54	0.75	1500	6.11	1.00	1220	8.07
0.55	1220	4.54	0.80	1525	6.50	1.00	1525	8.07
0.55	1500	4.54						

Sheet - ZINCANNEAL® (G2S ZF100)

Base Metal Thickness mm	Width mm	kg/m ²	Base Metal Thickness mm	Width mm	kg/m ²	Base Metal Thickness mm	Width mm	kg/m ²
0.50	1220	4.06	0.95	1220	7.59	1.40	1220	11.12
0.55	1220	4.45	1.00	1200	7.98	1.50	915	11.91
0.70	1220	5.63	1.10	1050	8.77	1.50	1200	11.91
0.75	1220	6.02	1.10	1200	8.77	1.50	1220	11.91
0.80	1200	6.41	1.10	1220	8.77	1.55	1200	12.29
0.90	915	7.19	1.15	1200	9.16	1.60	1200	12.69
0.90	1220	7.19	1.15	1220	9.16	1.90	1220	15.05
0.95	1200	7.59	1.20	1200	9.55	1.95	1200	15.44

Sheet - ZINCALUME® (G300 AZ150)

Base Metal Thickness mm	Width mm	kg/m ²	Base Metal Thickness mm	Width mm	kg/m ²	Base Metal Thickness mm	Width mm	kg/m ²
0.40	1200	3.31	0.75	1200	6.06	1.20	900	9.59
0.55	1200	4.49	1.00	900	8.02	1.20	1200	9.59
0.55	900	4.49	1.00	1200	8.02			

Sheet - COLORBOND® (CG300 AZ150)

Size mm x mm x mm	Colours	Mass sheets/tonne
1200 x 2400 x 0.55	Headland®, Manor Red®, Jasper®, Sandbank®, Classic Cream™, Surfmist®, Paperbark®, Dune®, Shale Grey™, Windspray®, Woodland Grey®, Bushland®, Pale Eucalypt®, Wilderness®, Cottage Green®, Monument™, Deep Ocean®, Ironstone®, Evening Haze®, Loft®	76
1200 x 2400 x 0.55	Surfmist®	76
x 3050 x 0.55		60
x 3660 x 0.55		51
1200 x 2440 x 0.55	Appliance	76
1200 x 1800 x 0.55	Sign White	100
x 2400 x 0.55		75
x 2400 x 0.80		63
x 3000 x 0.80		43

All trademarks or registered trademarks for Colorbond® colours are registered to BlueScope Steel Ltd.

Coil - COLORGUARD®

Exterior Durability
Application

Size mm x mm	Colours SMP/ Polyester	Substrate
1200 x 0.40 x 0.55	Tuscan Red, Heritage Red, Jasmin Brown, Sandlewood, Smooth Cream, Off White, Birch, Gull Grey, Armour Grey, Slate Grey,	G300 AZ150
940 x 0.42 x 0.48	Bushsmoke, Mist Green, Rivergum, Caulfield Green, Monolith, Mt Blue, Iron Grey, Dusk, Attic	G550 AZ150
1200 x 0.55	Appliance White*, Sign White*	G300 AZ150

* Available in sheet form where required

Coil - COLORGUARD® PLUS

Marine & Highly
Corrosive Application

Size mm x mm	Colours PVDF	Substrate
1200 x 0.55 940 x 0.42 x 0.48	Birch, Gull Grey, Armour Grey, Slate Grey, Rivergum, Iron Grey, Black Grey, Coral White	G300 AZ200 G550 AZ200

Coil - COLORGUARD® METALLIC

Architectural
Application

Size mm x mm	Colours SMP/ Polyester	Substrate
1200 x 0.55 940 x 0.42 x 0.48	Silver Coin, Champagne, Portico Grey, Alliance Grey, Glasshouse, Light Blue Metallic, Coppery Penny, Silver City, Silversmith, Temple Gold	G300 AZ150 G550 AZ150

Stainless Steel - Austenitic Sheet & Coil

SS

Grade	Thickness Range mm	Width mm
316	0.55 to 6.00	914, 1219, 1500, 1525
304	0.55 to 6.00	914, 1219, 1500, 1525

Stainless Steel - Ferritic Sheet & Coil

SS

Grade	Thickness Range mm	Width mm
430	0.55 to 0.9	914, 1219

Range of Stainless Steel includes:

Grades: 304, 316, 430

Finishes: 2B, No. 4 Polished, bright annealed

Stainless Steel - Flat Bar (Grades 304, 316)

SS

Size mm x mm	Mass kg/m	Size mm x mm	Mass kg/m	Size mm x mm	Mass kg/m
12 x 3	0.29	32 x 5	1.30	50 x 12	4.90
x 6	0.58	x 6	1.57	65 x 5	2.61
20 x 3	0.49	x 10	2.62	x 6	3.18
x 5	0.81	40 x 3	0.98	65 x 10	5.31
x 6	0.98	x 5	1.61	75 x 5	3.06
25 x 3	0.61	x 6	1.96	x 6	3.68
x 5	1.02	x 10	3.27	x 10	6.04
x 6	1.21	x 12	3.92	x 12	7.25
x 10	2.04	50 x 3	1.21	100 x 6	4.91
x 12	2.45	x 5	2.04	x 10	8.18
32 x 3	0.77	x 6	2.45		
		x 10	4.08		

Range of Stainless Steel includes:

Grades: 304, 304L, 316, 316L

Stainless Steel - Angle (Grades 304, 316)

Size mm	Mass kg/m	Size mm	Mass kg/m
25 x 25 x 3	1.13	40 x 40 x 3	1.85
x 5	1.77	x 5	2.98
x 6	2.06	x 6	3.49
30 x 30 x 3	1.36	50 x 50 x 3	2.36
x 5	2.17	x 5	3.79
x 6	2.53	x 6	4.46

Stainless Steel - Round Bar (Grades 304, 316 & 430)



Diameter mm	Mass kg/m	Diameter mm	Mass kg/m	Diameter mm	Mass kg/m
3.18	0.06	20.0	2.47	50.8	15.90
4.76	0.14	22.2	3.04	54.0	17.95
6.35	0.25	24.0	3.55	57.2	20.13
7.94	0.39	25.4	3.98	63.5	24.85
9.00	0.50	30.0	5.55	66.7	27.39
10.0	0.62	31.8	6.21	69.9	30.07
12.0	0.89	32.0	6.31	76.2	35.76
12.7	0.99	35.0	7.55	82.6	42.00
15.9	1.55	38.1	8.94	88.9	48.69
16.0	1.58	40.0	9.86	101.6	63.62
19.1	2.24	44.5	12.18	127	99.40

Stainless Steel Pipes

Stainless Steel Pipes to ASME B36.19

NOMINAL SIZE DN	OUT-SIDE DIAM. mm	NOMINAL WALL THICKNESS & INSIDE DIAMETER – millimetres							
		SCHEDULE 5S		SCHEDULE 10S		SCHEDULE 40S		SCHEDULE 80S	
		Wall Thickness	Inside Diameter	Wall Thickness	Inside Diameter	Wall Thickness	Inside Diameter	Wall Thickness	Inside Diameter
6	10.29	–	–	1.24	7.81	1.73	6.83	2.41	5.47
8	13.72	–	–	1.65	10.42	2.24	9.24	3.02	7.68
10	17.15	–	–	1.65	13.85	2.31	12.53	3.20	10.75
15	21.34	1.65	18.04	2.11	17.12	2.77	15.80	3.73	13.88
20	26.67	1.65	23.37	2.11	22.45	2.87	20.93	3.91	18.85
25	33.40	1.65	30.10	2.77	27.86	3.38	26.64	4.55	24.30
32	42.16	1.65	38.86	2.77	36.62	3.56	35.04	4.85	32.46
40	48.26	1.65	44.96	2.77	42.72	3.68	40.90	5.08	38.10
50	60.33	1.65	57.03	2.77	54.79	3.91	52.51	5.54	49.25
65	73.03	2.11	68.81	3.05	66.93	5.16	62.71	7.01	59.01
80	88.90	2.11	84.68	3.05	82.80	5.49	77.92	7.62	73.66
100	114.30	2.11	110.08	3.05	108.20	6.02	102.26	8.56	97.18
125	141.30	2.77	135.76	3.40	134.50	6.55	128.19	9.52	122.25
150	168.28	2.77	162.74	3.40	161.47	7.11	154.05	10.97	146.33
200	219.08	2.77	213.54	3.76	211.56	8.18	202.72	12.70	193.68
250	273.05	3.40	266.24	4.19	264.67	9.27	254.51	12.70*	247.65
300	323.85	3.96	315.93	4.57	314.71	9.52	304.08	12.70*	298.45
350	355.60	3.96	347.68	4.78	346.05	–	–	–	–
400	406.40	4.19	398.02	4.78	396.85	–	–	–	–
450	457.20	4.19	448.82	4.78	447.65	–	–	–	–
500	508.00	4.78	498.45	5.54	496.93	–	–	–	–
600	609.60	5.54	598.53	6.35	596.90	–	–	–	–
750	762.00	6.35	749.30	7.92	746.16	–	–	–	–



Standard Lengths

All LSB sizes listed in the tables are readily available from authorised LSB distribution outlets in standard lengths. However, the availability should be checked for large quantities of individual sizes and for non-standard lengths.

LSB AZ+ Section			Dimensions					Length Availability		
Designation			Mass	AZ+ Coating Mass	Height	Width	Thickness	8.0	12.0	13.5
<i>d</i>	<i>b_f</i>	<i>t</i>								
mm	mm	mm	kg/m	g/sqm	mm	mm	mm	m	m	m
300 x 75	x 3.0	LSB	14.5	120	300	75	3.0	✓	✓	✓
	2.5	LSB	12.2	120	300	75	2.5	✓	✓	✓
300 x 60	x 2.0	LSB	8.80	150	300	60	2.0	✓	✓	✓
250 x 75	x 3.0	LSB	13.3	120	250	75	3.0	✓	✓	✓
	2.5	LSB	11.2	120	250	75	2.5	✓	✓	✓
250 x 60	x 2.0	LSB	8.00	150	250	60	2.0	✓	✓	✓
200 x 60	x 2.5	LSB	8.86	120	200	60	2.5	✓	✓	✓
	2.0	LSB	7.21	150	200	60	2.0	✓	✓	✓
200 x 45	x 1.6	LSB	4.95	150	200	45	1.6	✓	✓	✓
150 x 45	x 2.0	LSB	5.31	150	150	45	2.0	✓	✓	✓
	1.6	LSB	4.32	150	150	45	1.6	✓	✓	✓

The full range of LSB sections is summarised in the table below. Sections can be ordered in non-standard lengths subject to minimum order requirements and mill rolling schedules.

Size	Non-Standard Lengths (m)
300 x 75 300 x 60 250 x 75 250 x 60 200 x 60 200 x 45 150 x 45	6.0 to 13.5

Notes: 1. Standard lengths may vary in some states. Please check with your local supplier when ordering.

Mechanical Properties

The DuoSteel grade LiteSteel beam is manufactured from a base steel which has a minimum yield stress $f_y = 380$ MPa and a tensile strength $f_u = 490$ MPa. The cold-forming process enhances the yield stress and tensile strength of the flanges of the LSB in the same way it does for the rectangular hollow sections, producing a formed section which complies with the following requirements:

Location	Minimum Yield Stress f_y MPa	Minimum Tensile Strength f_u MPa	Minimum Elongation as a proportion of Gauge Length of $5.65\sqrt{S_0}$ %
Web	380	490	14
Flanges	450	500	14

These values are monitored by testing in accordance with AS 1391.

Coatings Compared

Research has shown that LiteSteel beam with AZ+ is ideal for external use in moderate environments without the need for a painted top coat. Other pre-galvanised coatings simply don't make the grade, with expensive paints required to achieve the corrosion protection required by BCA guidelines.

Comparison and Suitability of Protective Coatings:

Coating	Moderate Environment		Severe Environment	
	More than 1 km from breaking surf, or more than 100 m from salt water not subject to breaking surf, or non-heavy industrial areas		Within 1 km from breaking surf, or within 100 m from salt water not subject to breaking surf, or heavy industrial areas	
	Internal	External	Internal	External
LSB AZ+	✓	✓	✓	Paint Top Coat Required
Hot Dip Galvanised (post manufacture)	✓	✓	✓	Suppliers Recommendation
Z200 (100 g/m ² per side)	✓	Paint Top Coat Required	Paint Top Coat Required	✗
Prime Painted	✓	Paint Top Coat Required	Paint Top Coat Required	✗

- Notes:
- ✓ means that the protective coating satisfies the requirements of Table 3.4.4.2 of the BCA Volume Two.
 - 'Paint Top Coat Required' means that a paint top coat treatment is needed to satisfy the requirements of Table 3.4.4.2 of the BCA Volume Two.
 - 'Prime Painted' refers to standard water based EnviroKote paint primer.
 - The comparative performance of the AZ+ coating with the other coatings is obtained from the following references:
 - Smorgon Steel Reinforcing, Sunshine Laboratory (2007), "Test Report No. TR07-01 (including NATA Endorsed Test Certificate 06N001)", Victoria, Australia, 10 January 2007.
 - Townsend, H. E. and Borzillo, A. R. (1997), "55% Al-Zn Alloy Coated Sheet Steel: The Versatile, Long Lasting Building Panel Steel", 5th International Conference on Zinc Coated Steel Sheet, Birmingham, England, 12-13 June 1997.
 - The distances listed in this table defining moderate and severe environments are minimum distances and should be used as a guide only. The appropriate distance from breaking surf or from salt water not subject to breaking surf depends on regional factors, and may be significantly larger. In some locations, the acceptable distance from breaking surf could extend as far as 10 to 50 km inland. Local factors such as prevailing winds, topography, shielding by other buildings and trees, and exposure to rain will also influence the classification of the exposure environment. The nature of a structure and the design details of that structure may also have a significant affect on the susceptibility of individual members to corrosion. AZ+ is not recommended for use in non-sealed decks and verandahs within the splash zone of swimming pools. If you are uncertain as to the suitability of a protective coating for your intended application, please refer to AS/NZS 2312. As a guide, AZ+ is considered to last 3 to 4 times longer than galvanised coatings of equal coating mass under the same exposure conditions.

Welding Information

The LSB can be readily welded using appropriate arc welding processes. The design of welded connections for the LSB must comply with Section 5.2 of AS/NZS 4600.

The following welding consumables are suitable for the DuoSteel grade LSB:

Welding Process	Australian Standard	Consumables	Nominal Weld Tensile Strength f_{uw} (MPa)
MMAW (Manual Metal Arc Welding)	AS 1553.1	E48XX	480
GMAW (Gas Metal Arc Welding)	AS 2717.1	W50X	480
FCAW (Flux Cored Arc Welding)	AS 2203.1	W50X	480

These consumables are also acceptable and commonly used for welding to Grade 300 Angles and Flats and to Grade 250 Plate.

Welding Safety

Weld fume monitoring tests conducted on the LSB AZ+ coating indicate that selected metal particulate concentrations were below the respective exposure standards for each particular metalloid contaminant. Measured ozone, nitric oxide, carbon monoxide and nitrogen dioxide concentrations were also well below the respective exposure standards. Unless extended and continuous welding periods are anticipated, no further protection other than standard welding personal protective equipment (PPE) would be required to control zinc exposures under normal operating conditions. Welding in confined spaces or other spaces with poor general ventilation should be avoided unless appropriate controls (including supplied air) can be instituted. Those workers using a respiratory protective device (RPD) must be trained in its selection, use, and maintenance. All tests were conducted as part of an occupational hygiene survey by NSCA on behalf of LiteSteel Technologies.



DuraGal Carport®

The DuraGal Carport® brings to the market a system that offers:

- A lightweight, efficient structure constructed from high strength GAL140™ RHS.
- A cost-effective coating system. The internal and external hot dip galvanized coating applied provides a product ready for use.
- Proprietary fittings allow fast and efficient assembly.
- A selection of sizes includes cyclone ratings to suit all markets.

Size Range

Standard Height 2.150m

- 5.4 x 3.0 & 5.4 (m)
- 6.0 x 3.0, 3.6 & 6.0 (m)
- 7.0 x 3.6 & 6.0 (m)

GAL140™ sizes

Rafters: 150x50x2.0/3.0

100x50x1.6/2.0

Purlins: 150x50x2.0/3.0

100x50x1.6/2.0

Posts: 90x90x2.0

The DuraGal Carport® uses high strength C450L0 grade galvanized GAL140™ Hollow Sections. The sections are strong and lightweight making them easy and safe to handle on site. The DuraGal Carport® is designed using a range of speciality fittings to allow safe and easy construction.

Advantages of the DuraGal Carport®

- Material pre-cut and delivered direct to site as a flat pack, ready to install.
- Reduced edges minimise the chance of vermin perching and nesting.
- No protruding fasteners.
- Easy & quick to erect.
- Visually pleasing clean lines.
- Simple Purlin fixing.
- Self-drilling screws allow speedier assembly.
- Easily cleaned.
- No welding and no time-consuming bolted connections.

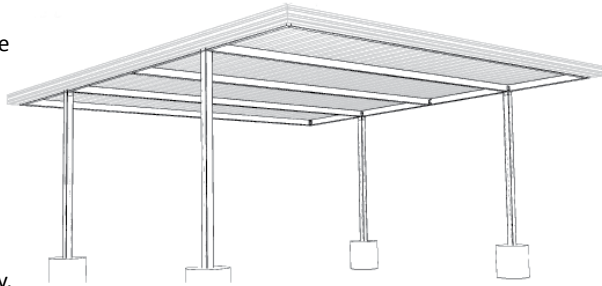

DuraGal Flooring System®

Fully Engineered System

The DuraGal Flooring System® is a fully engineered steel flooring system* developed to provide a termite resistant, economical and easy-to-install alternative to conventional timber bearers & joists.

Easy to Install

The DuraGal Flooring System® uses high strength C450L0 grade galvanized GAL140™ Hollow Sections. The sections are strong and lightweight making them easy to handle on site.

GAL140™ is easy to cut and drill, and best of all the system has been designed so that it simply screws together on site using a screw gun fitted with a hex head bit.

The DuraGal Flooring System® features a range of speciality galvanized fittings designed to allow you to get on with the job easily and quickly. Fast and accurate levelling of the floor using the adjustable piers during and after construction is a great feature.

Sheet flooring can still be attached in the traditional way using building adhesive and gun-nailing. Most reputable nail tool suppliers have hardened tipped nails to suit common nail guns to sheet flooring to steel joists up to and including 2mm thick.

Spans

Joists are typically 100x50x1.6mm with continuous spans of 2800mm and bearers are typically 150x50x2.0mm with continuous spans of 3000mm.

Other sizes may be specified with differing spans subject to the floor layout and site conditions. Your DuraGal Flooring System® distributor will be able to nominate the most economical sizes and layout upon receipt of the house plans.

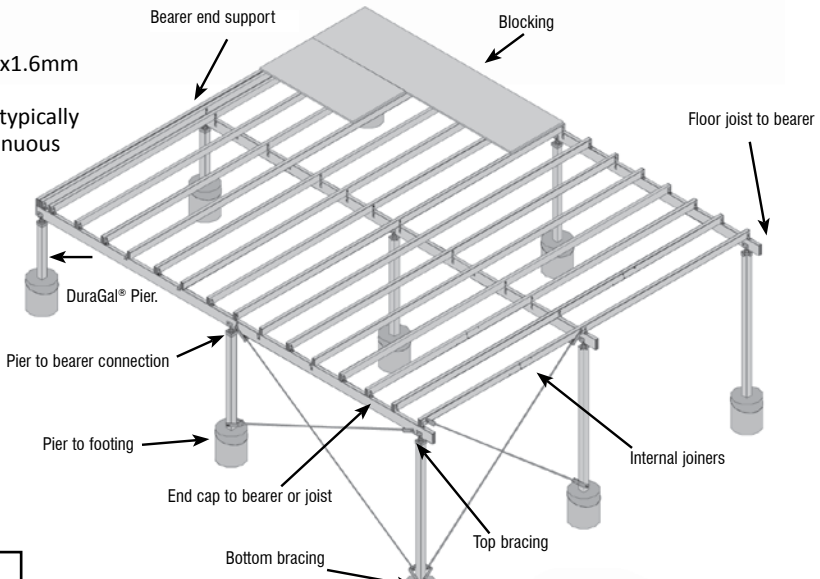

Typical sections of GAL140™
Piers: 90 x 90 x 2.0mm
Bearers: 150 x 50 x 2.0mm
Joists: 100 x 50 x 1.6mm

Pier adjustable top connection fits 90x90x2.0 GAL140™ SHS - 100mm in adjustment, maximum recommended <70mm - Suits 50mm wide bearers - Maximum height 4.5m

GAL140™ PIER

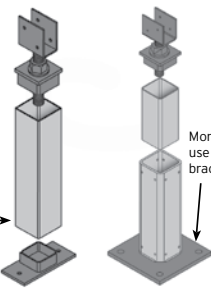

INTERNAL JOINERS
 Internal joiner (bearer and joist)

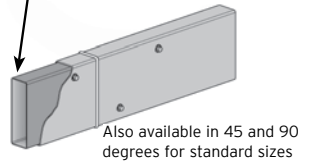

*The DuraGal Flooring System® requires independent engineering certification to determine compliance of site specific conditions with statutory requirements.

FLOOR JOIST TO BEARER CONNECTIONS

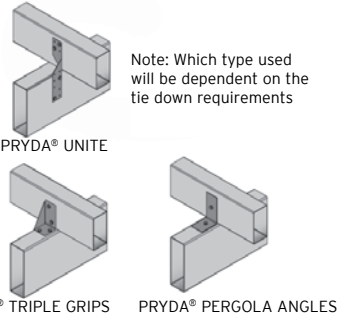

BEARER END SUPPORT

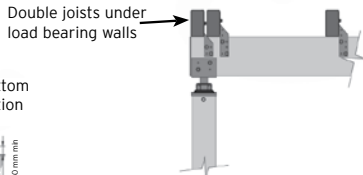

PIER TO FOOTING DETAIL (BASE PLATE)

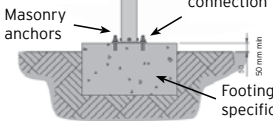

PIER TO FOOTING DETAIL (CAST IN)

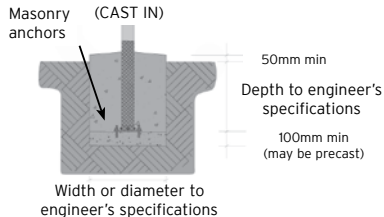

PIER TO BEARER CONNECTION

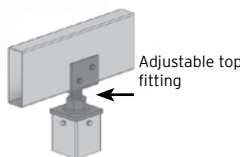

SPLIT LEVEL ARRANGEMENT

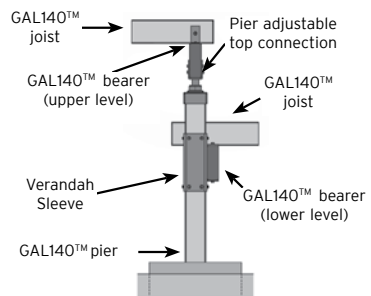

Purlins - C Sections



Designation	Size mm x mm x mm	Mass kg/m
C 10010	102 x 51 x 1.0	1.77
C 10012	102 x 51 x 1.2	2.10
C 10015	102 x 51 x 1.5	2.61
C 10019	102 x 51 x 1.9	3.29
C 15012	152 x 61 x 1.2	2.89
C 15015	152 x 61 x 1.5	3.58
C 15019	152 x 62 x 1.9	4.51
C 15024	152 x 63 x 2.4	5.67

Designation	Size mm x mm x mm	Mass kg/m
C 20015	203 x 71 x 1.5	4.49
C 20019	203 x 73 x 1.9	5.73
C 20024	203 x 75 x 2.4	7.20
C 25019	254 x 73 x 1.9	6.50
C 25024	254 x 74 x 2.4	8.16
C 30024	300 x 100 x 2.4	10.1
C 30030	300 x 101 x 3.0	12.6
C 35030	350 x 126 x 3.0	15.1

Purlins - Z Sections



Designation	Size mm x mm x mm	Mass kg/m
Z 10010	102 x 53 x 1.0	1.77
Z 10012	102 x 53 x 1.2	2.10
Z 10015	102 x 53 x 1.5	2.61
Z 10019	102 x 53 x 1.9	3.29
Z 15012	152 x 66 x 1.2	2.89
Z 15015	152 x 66 x 1.5	3.58
Z 15019	152 x 66 x 1.9	4.51
Z 15024	152 x 70 x 2.4	5.67

Designation	Size mm x mm x mm	Mass kg/m
Z 20015	203 x 77 x 1.5	4.49
Z 20019	203 x 80 x 1.9	5.73
Z 20024	203 x 82 x 2.4	7.20
Z 25019	254 x 79 x 1.9	6.50
Z 25024	254 x 79 x 2.4	8.16
Z 30024	300 x 105 x 2.4	10.1
Z 30030	300 x 107 x 3.0	12.6
Z 35030	350 x 134 x 3.0	15.1

Note: Purlins are made from high tensile steel to be fastened rather than welded.



DuraGal® Plus Lintels



12m

Size mm x mm	Nominal Thickness mm	Mass kg/m	Pack Size (Lns)
100 x 100	6.0	8.92	16
	8.0	11.7	14

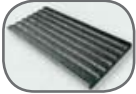
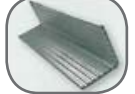
Size mm x mm	Nominal Thickness mm	Mass kg/m	Pack Size (Lns)
150 x 100	6.0	11.3	16
	8.0	14.9	12

Lintels

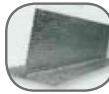
Max Clear Opening (mm)	Flat		Angle			
	85 x 8 Multi Rib	100x100x6 Multi Rib	150x100x6 Multi Rib	100x75x10 Traditional	150x90x10 Traditional	150x100x10 Traditional
up to 600mm	800					
600 - 700	900	900		900		
700 - 800	1000	1200				
800 - 900	1100	1200		1200		
900 - 1000	1200	1200		1200		
1000 - 1100		1500		1500		
1100 - 1200		1500		1500		
1200 - 1500		1800	1800	1800	1800	
1500 - 1800		2100	2100	2100	2100	2100
1800 - 2100		2400	2400	2400	2400	2400
2100 - 2400		2700	2700	2700	2700	2700
2400 - 2700			3000	3000	3000	3000
2700 - 3000			3300		3300	3300
3000 - 3300			3600		3600	3600
3300 - 3600			4000		4000	4000
4000 - 4200					4500	4500
4200 - 4500					5000	5000
4800 - 5100					5500	5500
5400 - 5700					6000	6000

Max Clear Opening (mm)	Rendabar		T-Bar				
	100 x 100 x 8 Rendabar	150 x 100 x 8 Rendabar	200 x 200 x 7 Multi Rib	200 x 200 x 9 Multi Rib	200 x 200 x 10 Traditional	250/10x200/10 Traditional	250/12x200/10 Traditional
up to 600mm	900						
600 - 700	900		900				
700 - 800	1200		1200				
800 - 900	1200		1200				
900 - 1000	1200		1200				
1000 - 1100	1500		1500				
1100 - 1200	1500		1500				
1200 - 1500	1800	1800	1800				
1500 - 1800	2100	2100	2100				
1800 - 2100	2400	2400	2400				
2100 - 2400		2700	2700		2700	2800	
2400 - 2700		3000	3000		3000		
2700 - 3000		3300	3300		3300		
3000 - 3300		3600	3600	3600			
3300 - 3600		4000	3900	3900			
3600 - 4000				4200			
4000 - 4200				4500			
4200 - 4500				4800			
4500 - 4800				5100			
4800 - 5100				5400		5200	5200
5100 - 5400				5700		5400	5400
5400 - 5700				6000		5600	
5700 - 6000				6300		6000	6000
						6300	

Mesh - Expanded Metal

Reference Number	Sheet Size m x m	Nominal Opening Size mm x mm	Strand Width mm	Mass Ea/kg
GR50080/ (WK4514)	2.0 x 1.20	45 x 135	8.0	50.4
	x 0.90	x 135	8.0	37.8
	x 0.75	x 135	8.0	31.5
	x 0.60	x 135	8.0	25.2
GR50110/ (WK4519)	2.3 x 1.20	45 x 135	11.0	68.4
	x 0.90	x 135	11.0	51.3
	x 0.75	x 135	11.0	42.8
	x 0.60	x 135	11.0	34.2
GM50075/ (WK3022)	3.0 x 1.20	30 x 75	7.5	79.2
	x 0.90	x 75	7.5	59.4
	x 0.75	x 75	7.5	49.5
	x 0.60	x 75	7.5	39.6
GM50105/ (WK3008)	2.3 x 1.20	30 x 75	10.5	100.8
	x 0.90	x 75	10.5	75.6
	x 0.75	x 75	10.5	63.0
	x 0.60	x 75	10.5	50.4

Mesh - HANDI MESH®

Reference Number	Sheet Size m x m	Wire Spacing mm x mm	Wire Diameter mm	Weight kg
G112AHS	2.0 x 1.2	25 x 25	2.30	8
G122AHS	x 1.2	25 x 50	2.30	6
G234HS	x 1.2	50 x 75	3.50	8
G224HS	x 1.2	50 x 50	3.50	10
G444HS	x 1.2	100 x 100	4.00	5

Mesh - Trench

Reference Number	Width (metre)	Wire Spacing mm x mm	Diameter Long/Cross mm/mm	Mass kg
L8TM200	0.2	100 x 300	8/4	6.8
L8TM300	0.3	x 300	8/4	9.2
L8TM400	0.4	x 300	8/4	11.6
L8TM500	0.5	x 300	8/4	13.9

Mesh - Reinforcing

Reference Number	Sheet Size m x m	Wire Spacing mm x mm	Wire Diameter mm	Weight kg
SL 81	6 x 2.4	100 x 100	7.60	105
F 41	x 2.4	x 100	4.00	29
SL 102	x 2.4	200 x 200	9.50	80
SL 92	x 2.4	x 200	8.60	66
SL 82	x 2.4	x 200	7.60	52
SL 72	x 2.4	x 200	6.75	41
SL 62	x 2.4	x 200	6.00	33
SL 52 ⁺	x 2.4	x 200	4.77	21
SL 63 [*]	x 2.3	300 x 300	6.00	21
SL 53 ^{**}	x 2.3	x 300	5.00	14

Mesh - General Purpose

Reference Number	Sheet Size m x m	Wire Spacing mm x mm	Wire Diameter mm	Weight kg
Galv. Sheets				
G112A	3 x 2.4	25 x 25	2.50	23
G113	x 2.4	x 25	3.15	36
G123	x 2.4	50 x 25	3.15	27
G224	x 2.4	x 50	4.00	29
G225	x 2.4	x 50	5.00	45
G234	x 2.4	x 75	4.00	24
G235	x 2.4	x 75	5.00	39
Galv. Rolls				
G232A9	30 x 0.9	50 x 75	2.50	36
G232A12	x 1.2	x 75	2.50	48
G232A18	x 1.8	x 75	2.50	71
G442A9	x 0.9	100 x 100	2.50	22
G442A12	x 1.2	x 100	2.50	29
G442A18	x 1.8	x 100	2.50	42

Deformed Bar



Reference Number	Diameter mm	Mass kg/m	Metres per Tonne	Reference Number	Diameter mm	Mass kg/m	Metres per Tonne
N10S	10	0.63	1582	N28S	28	4.95	202
N12S	12	0.91	1099	N32S	32	6.47	155
N16S	16	1.62	617	N36S	36	8.91	122
N20S	20	2.53	395	N40S	40	10.11	99
N24S	24	3.64	275				

*Only available in WA +Smooth round wire

Geometry & Mensuration

Shape	Area or Volume	Formulae	Results - Area or Volume
Rectangles	Area	Multiply length by width	$A (m) \times B (m) = \text{Square metres}$
Squares	Area	Multiply length by width	$A (m) \times B (m) = \text{Square metres}$
Cubes	Volume	Length x Width x Height	$A (m) \times B (m) \times H (m) = \text{Cubic metres}$
Circles	Circumference	Multiply diameter by Pi (or 3.142858)	$D (m) \times \text{Pi} = \text{metres}$
Circles	Area	$\text{Pi} \times \text{Radius} \times \text{Radius}$ [or R^2]	$(R^2) \times \text{Pi} = \text{Square metres}$
Sector of a circle	Area	Length of Arc x Half Radius	$A (m) \times R/2 = \text{Square metres}$
Triangles	Area	Base/2 x Height	$B/2 (m) \times H = \text{Square metres}$
Ellipse	Area	Long axis x Short axis x 0.7854	$D1 (m) \times D2 (m) \times 0.7854 = \text{Square metres}$
Ellipse	Volume	Long axis x Short axis x 0.7854 x Length	$D1 (m) \times D2 (m) \times 0.7854 \times L = \text{Square metres}$
Cylinder	Area	Circumference of base x Height	$D (m) \times \text{Pi} \times H (m) = \text{Square metres}$
Cylinder	Volume	Area of base x Height	$(R^2) \times \text{Pi} \times H (m) = \text{Cubic metres}$
Sphere	Area	Diameter x Diameter x Pi	$D (m) \times D (m) \times \text{Pi} = \text{Square metres}$
Sphere	Volume	Diameter x Diameter x Diameter x 0.5236	$D (m) \times D (m) \times D (m) \times 0.5236 = \text{Cubic metres}$
Pyramid	Area	Perimeter of base x Slant Height/3	$[A (m) + B (m) \times 2 \times \text{Slant height}]/3 = \text{Square metres}$
Pyramid	Volume	Area of base x Vertical Height/3	$[A (m) + B (m) \times H (m)]/3 = \text{Cubic metres}$

Handy Tips

To calculate the mass of steel circular hollow sections (CHS) (as used in Australian Standards AS 1163)

Circular sections

Mass = (OD - wt) x wt x 0.0246615.

where: Mass = mass/metre kg/m
 OD = outside diameter mm
 wt = section thickness mm

To calculate the mass of steel plate sections

Mass = t x 7.850 x (L x W)

where: Mass = kg
 t = thickness of plate mm
 L = length of plate m
 W = width of plate m

To calculate the mass for Floor plate, add 2 kg/m²

To calculate the mass of flats, squares and rounds.

Flats: Width (mm) x Thickness (mm) x 0.00785 = kg/m

Squares: Size (mm²) x 0.00785 = kg/m

Rounds: Diameter (mm²) x 0.006165 = kg/m

To determine the length of conveyor belting

Measure in inches from the outside of the roll to the opposite side of the centre opening **S**. Count the number of layers or turns of belt **N**.

C is constant = 0.2618

$L = S \times N \times C = \text{Length in feet}/3.28 = \text{metres}$

eg. 26" x 61 x 0.2618 = 415.22' divide by 3.28 = 126.6m

Property of Steel	Symbol	Value
Young's Modulus of Elasticity	E	200 x 10 ³ MPa
Shear Modulus of Elasticity	G	80 x 10 ³ MPa
Density	ρ	7850 kg/m ³
Poisson's Ratio	ν	0.25
Coefficient of Thermal Expansion	α	11.7 x 10 ⁻⁶ per °C

Gauge Conversions

Conversion Factors

mm	Gauge	IMPERIAL	
		Decimal	inch
0.40	26		
0.60	24		
0.80	22	0.032	1/32
1.00	20		
1.20	18	0.047	3/64
1.40	17	0.055	
1.60	16	0.063	1/16
1.80	15	0.071	
2.00	14	0.080	5/64
2.30	13	0.092	3/32
2.50	12	0.098	
2.80	11	0.110	
3.00	10	1.125	1/8
3.50	9	0.138	
4.00	8	0.160	5/32
5.00	6	0.197	3/16
6.00	4	0.236	
6.30	3	0.250	1/4
8.00	2	0.315	5/16
9.00	1	0.354	
10.00	0	0.394	3/8
12.70		0.500	1/2
16.00		0.625	5/8
19.00		0.750	3/4
22.00		0.875	7/8
25.40		1.000	1

General Information: Pipe & RHS

Colour Code: RHS

COLOUR	WALL THICKNESS	
	mm	inch
Purple	1.6	0.063
Chocolate Brown	1.8	0.072
Yellow	2.0	0.080
Silver	2.3	0.091
Pink	2.5	0.098
Gold	2.8	0.110
Dark blue	3.0	0.118
Grey	3.5	0.138
Green	4.0	0.160
Orange	5.0	0.197
White	6.0	0.236
Pink	7.0	0.276
Red	8.0	0.315
Purple	9.0	0.354

Colour Code: Pipe

Colour	Gauge
Green end	Extra light
Yellow end	Light
Blue band	Medium
Red band	Heavy
White band	Extra heavy

Telescoping RHS

Female (Outer)			Nominal Clearance		Male (Inner)	
d	b	t	Top	Side	d	b
mm	mm	mm	mm	mm	mm	mm

SQUARE HOLLOW SECTIONS

NO SECTION AVAILABLE						
15	15	1.8				
20	20	1.6	1.8	1.8	15	15
25	25	1.6	1.8	1.8	20	20
25	25	2.0	1.0	1.0	20	20
25	25	2.5	0.0	0.0	20	20
30	30	1.6	1.8	1.8	25	25
30	30	2.0	1.0	1.0	25	25
35	35	1.6	1.8	1.8	30	30
35	35	2.0	1.0	1.0	30	30
35	35	2.5	0.0	0.0	30	30
35	35	3.0	4.0	4.0	25	25
40	40	1.6	1.8	1.8	35	35
40	40	2.0	1.0	1.0	35	35
40	40	2.5	0.0	0.0	35	35
40	40	3.0	4.0	4.0	30	30
40	40	4.0	2.0	2.0	30	30
50	50	1.6	6.8	6.8	40	40
50	50	2.0	6.0	6.0	40	40
50	50	2.5	5.0	5.0	40	40
50	50	3.0	4.0	4.0	40	40
50	50	4.0	2.0	2.0	40	40
50	50	5.0	0.0	0.0	40	40
65	65	1.6	11.8	11.8	50	50
65	65	2.0	11.0	11.0	50	50
65	65	2.5	10.0	10.0	50	50
65	65	3.0	9.0	9.0	50	50
65	65	4.0	7.0	7.0	50	50
65	65	5.0	5.0	5.0	50	50
65	65	6.0	3.0	3.0	50	50
75	75	2.0	6.0	6.0	65	65
75	75	2.5	5.0	5.0	65	65
75	75	3.0	4.0	4.0	65	65
75	75	3.5	3.0	3.0	65	65
75	75	4.0	2.0	2.0	65	65
75	75	5.0	0.0	0.0	65	65
75	75	6.0	13.0	13.0	50	50

Female (Outer)			Nominal Clearance		Male (Inner)	
d	b	t	Top	Side	d	b
mm	mm	mm	mm	mm	mm	mm
89	89	3.5	7.0	7.0	75	75
89	89	5.0	4.0	4.0	75	75
89	89	6.0	2.0	2.0	75	75
90	90	2.0	11.0	11.0	75	75
90	90	2.5	10.0	10.0	75	75
100	100	2.0	7.1	7.1	89	89
100	100	2.5	6.1	6.1	89	89
100	100	3.0	5.1	5.1	89	89
100	100	4.0	3.1	3.1	89	89
100	100	5.0	1.1	1.1	89	89
100	100	6.0	13.0	13.0	75	75
100	100	9.0	7.0	7.0	75	75
125	125	4.0	17.0	17.0	100	100
125	125	5.0	15.0	15.0	100	100
125	125	6.0	13.0	13.0	100	100
125	125	9.0	7.0	7.0	100	100
150	150	5.0	15.0	15.0	125	125
150	150	6.0	13.0	13.0	125	125
150	150	9.0	7.0	7.0	125	125
200	200	5.0	40.0	40.0	150	150
200	200	6.0	38.0	38.0	150	150
200	200	9.0	32.0	32.0	150	150
250	250	6.0	38.0	38.0	200	200
250	250	9.0	32.0	32.0	200	200

RECTANGULAR HOLLOW SECTIONS

NO SECTION AVAILABLE						
50	20	1.6				
50	20	2.0				
50	20	2.5				
50	20	3.0				
50	25	1.6				
50	25	2.0				
50	25	2.5				
50	25	3.0				
65	35	2.0	11.0	6.0	50	25
65	35	2.5	10.0	5.0	50	25
65	35	3.0	9.0	4.0	50	25
65	35	4.0	7.0	2.0	50	25
75	25	1.6	21.8	1.8	50	20
75	25	2.0	21.0	1.0	50	20
75	25	2.5	20.0	0.0	50	20

Female (Outer)			Nominal Clearance		Male (Inner)	
d	b	t	Top	Side	d	b
mm	mm	mm	mm	mm	mm	mm
75	50	1.6	6.8	11.8	65	35
75	50	2.0	6.0	11.0	65	35
75	50	2.5	5.0	10.0	65	35
75	50	3.0	4.0	9.0	65	35
75	50	4.0	2.0	7.0	65	35
75	50	5.0	0.0	5.0	65	35
75	50	6.0	13.0	13.0	50	25
100	50	1.6	20.8	8.8	76	38
100	50	2.0	20.0	8.0	76	38
100	50	2.5	19.0	7.0	76	38
100	50	3.0	18.0	6.0	76	38
100	50	3.5	17.0	5.0	76	38
100	50	4.0	16.0	4.0	76	38
100	50	5.0	14.0	2.0	76	38
100	50	6.0	12.0	0.0	76	38
125	75	2.0	21.0	21.0	100	50
125	75	2.5	20.0	20.0	100	50
125	75	3.0	19.0	19.0	100	50
125	75	4.0	17.0	17.0	100	50
125	75	5.0	15.0	15.0	100	50
125	75	6.0	13.0	13.0	100	50
150	100	4.0	15.0	41.0	127	51
150	100	5.0	13.0	39.0	127	51
150	100	6.0	11.0	37.0	127	51
150	100	9.0	5.0	31.0	127	51
200	100	4.0	40.0	16.0	152	76
200	100	5.0	38.0	14.0	152	76
200	100	6.0	36.0	12.0	152	76
200	100	9.0	30.0	6.0	152	76
250	150	5.0	40.0	40.0	200	100
250	150	6.0	38.0	38.0	200	100
250	150	9.0	32.0	32.0	200	100

NOTE

RHS is not a precision tube and all dimensions shown in the chart, although in accordance with the specifications, may vary marginally within the tolerance bands permitted.

Sizes shown in bold print are sizes that provide a clearance of less than 2.0mm. The internal weld bead and variation in corner radii between sections will need to be considered when closer fits are indicated. Where telescoping over some length is desired, additional allowance may be needed for straightness. For tight fits it is recommended that some form of testing be carried out prior to committing material.

HOW TO USE THIS CHART

1. Select the appropriate table for the type of hollow section required. Select the size of female (or outside) member closest to your requirements for the left hand column.
2. Depending on the application select the clearance required between the two members. Members may need to slide freely inside each other, or be locked with a pin, spot welded or fixed with wedges. This means, in some cases, a

'sloppy' fit may be suitable, while for others the tightest fit possible may be more appropriate.

3. Having selected the most suitable clearance for your application, take the appropriate size of the male (inner) section from the right hand column, eg:

Female Section (outer)	Clearance mm	Male Section (inner)
75 x 75 x 3.0	4.0x4.0	65 x 65

Note that clearance is total available difference between member dimensions, not the gap on both sides.

4. Where two telescoping sections are being used, thickness should be similar and will be determined by normal structural requirements. If a third section is to be used, consideration of both clearance and thickness within the size list available may be required.
5. RHS has the obvious advantage that its shape prevents rotation of the sections. When pipe is used it may need to be fixed against twisting by welding or bolting.

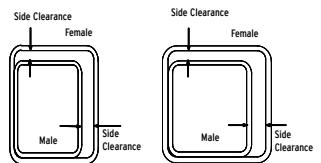

6. Press Fit. For short pieces with no need for separation or sliding an interference fit can be achieved using the available ductility of the steel.

Note: Sizes where clearance is shown as 0.0 will generally require press fit.

Telescoping CHS

Female (Outer) Size				Male (inner) Size		
DN	Quality	d _o mm	t mm	DN	d _i mm	Min. Clearance mm
15	Light	21.3 x	2.0	NO SECTION AVAILABLE		
	Medium		2.6			
	Heavy		2.3			
20	Extra Light	26.9 x	2.0	15	21.3	0.4
25	Extra Light	33.7 x	2.0	20	26.9	1.6
	Light		2.6	20	26.9	0.4
	Medium		3.2	15	21.3	4.8
32	Extra Light	42.4 x	2.0	25	33.7	3.5
	Light		2.6	25	33.7	2.3
	Medium		3.2	25	33.7	1.1
40	Extra Light	48.3 x	2.3	32	42.4	0.1
	Light		2.9	25	33.7	7.6
	Medium		3.2	25	33.7	7.0
50	Extra Light	60.3 x	2.3	40	48.3	6.4
	Light		2.9	40	48.3	5.2
	Medium		3.6	40	48.3	3.8
50	Heavy	60.3 x	4.5	40	48.3	2.0
	Extra Heavy		5.4	40	48.3	0.2

Female (Outer) Size				Male (inner) Size		
DN	Quality	d _o mm	t mm	DN	d _i mm	Min. Clearance mm
65	Extra Light	76.1 x	2.3	50	60.3	9.8
	Gallube® Plus		2.6	50	60.3	9.2
	Light		3.2	50	60.3	8.0
	Medium		3.6	50	60.3	7.2
	Heavy		4.5	50	60.3	5.4
80	Extra Heavy	88.9 x	5.9	50	60.3	2.6
	Extra Light		2.6	65	76.1	6.0
	Light		3.2	65	76.1	4.8
90	Medium	101.6 x	4.0	65	76.1	3.2
	Heavy		5.0	65	76.1	1.2
	Extra Heavy		5.9	50	60.3	15.3
90	Extra Light	101.6 x	2.6	80	88.9	5.6
	Light		3.2	80	88.9	4.4
	Medium		4.0	80	88.9	2.8
	Heavy		5.0	80	88.9	0.8
100	Extra Light	114.3 x	3.2	90	101.6	4.1
	Light		3.6	90	101.6	3.3
	Medium		4.5	90	101.6	1.5
	Heavy		5.4	80	88.9	12.6
125	Extra Light	139.7 x	3.0	100	114.3	16.9
	Light		3.5	100	114.3	15.9
	Medium		5.0	100	114.3	12.9
	Heavy		5.4	100	114.3	12.1
150	Light	165.1 x	3.5	125	139.7	15.4
	Medium		5.0	125	139.7	12.4
	Heavy		5.4	125	139.7	11.6

NOTE

Clearance = (AS1163 Min d_i - 2t) - (AS1163 Max d_o)

CHS is not a precision tube and all dimensions shown in the chart, although in accordance with the specifications, may vary marginally within the tolerance bands permitted.

Sizes shown in bold print are sizes that provide a clearance of less than 2.0mm. The internal weld bead will need to be considered when closer fits are indicated. Where telescoping over some length is desired, additional allowance may be needed for straightness. For tight fits it is recommended that some form of testing be carried out prior to committing material.

HOW TO USE THIS CHART

- Select the size of female (or outer) member closest to your requirements from the left hand column.
- Depending on the application select the clearance required between the two members. Members may need to slide freely inside each other, or be locked with a pin,

spot welded or fixed with wedges. This means, in some cases, a 'sloppy' fit may be suitable, while for others the tightest fit possible may be more appropriate. (See Note 6 Press Fit).

- Having selected the most suitable clearance for your application, take the appropriate size of the male (inner) section from the centre column, eg:

Female Section (outer)	Male Section (inner)	Clearance mm
76.1x5.9	60.3	2.6

Note that clearance is total available difference between member dimensions, not the gap on both sides.

- Where two telescoping sections are being used, thickness should be similar and will be determined by normal structural requirements. If a third section is to be used, consideration of both clearance and thickness within the size list available may be required.
- Pipe may need to be fixed against twisting by welding or bolting.

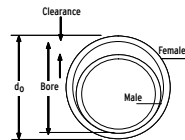

- Press Fit. For short pieces with no need for separation or sliding an interference fit can be achieved using the available ductility of the steel.

Australian Standards

AS 1074	Steel tube and tubular for ordinary service	AS/NZS 1163	Structural steel hollow sections
AS/NZS 4600	Cold formed steel structures	AS/NZS 3679.1	Structural steel - hot rolled bars & sections
AS/NZS 1594	Hot-rolled steel flat products	AS/NZS 3679.2	Structural steels - Welded I sections
AS 1397	Steel sheet & strip- hot dipped zinc coated or aluminium/zinc coated	AS/NZS 3678	Structural steel- Hot rolled plates, floor plates and slabs
AS 1442	Carbon steels and carbon manganese steels-Hot rolled bars	AS 1303	Steel reinforcing wire for concrete
AS 1450	Steel tubes for Mechanical Purposes		

Mass Conversions kilos/pounds

Kilogram kg	Pound lb	Pound lb	Kilogram kg
1	2.205	1	0.4536
2	4.409	2	0.9072
3	6.614	3	1.361
4	8.818	4	1.814
5	11.02	5	2.268
6	13.23	6	2.722
7	15.43	7	3.175
8	17.64	8	3.629
9	19.84	9	4.082
10	22.05	10	4.536
50	110.2	50	22.68
100	220.5	100	45.36

Mass Conversions tonnes/tons

Tonnes	Tons	Tons	Tonnes
1	0.9842	1	1.016
2	1.968	2	2.032
3	2.953	3	3.048
4	3.937	4	4.064
5	4.921	5	5.080
6	5.905	6	6.096
7	6.889	7	7.112
8	7.874	8	8.128
9	8.858	9	9.144
10	9.842	10	10.16
50	49.21	50	50.80
100	98.42	100	101.60

Length Conversions cms/inches

centimetres (cm)	inches (in)	inches (in)	centimetres (cm)
1	0.3937	1	2.54
2	0.7874	2	5.08
3	1.1810	3	7.62
4	1.5750	4	10.16
5	1.9690	5	12.70
6	2.3620	6	15.24
7	2.7559	7	17.78
8	3.1500	8	20.32
9	3.5430	9	22.86
10	3.9370	10	25.40
50	19.690	50	127.0
100	39.370	100	254.0

Length Conversions km/miles

Kilometre (km)	Miles	Miles	Kilometre (km)
1	0.6214	1	1.609
2	1.243	2	3.219
3	1.864	3	4.828
4	2.485	4	6.437
5	3.107	5	8.047
6	3.728	6	9.656
7	4.350	7	11.27
8	4.971	8	12.87
9	5.592	9	14.48
10	6.214	10	16.09
50	31.07	50	80.47
100	62.14	100	160.90

Pressure Conversion psi/MPa

psi	MPa	MPa	psi
1	0.006895	0.1	14.5
50	0.3447	0.2	29.01
100	0.6895	0.3	43.51
200	1.379	0.4	58.02
300	2.068	0.5	72.52
400	2.758	0.6	87.02
500	3.447	1.0	145.0
600	4.137	1.5	217.6
700	4.826	2.0	290.1
800	5.516	2.5	362.6
900	6.205	3.0	435.1
1000	6.895	3.5	507.6
1100	7.584	4.0	580.2
1200	8.274	4.5	652.7
1300	8.963	5.0	725.2
1400	9.653	5.5	797.7

Pressure Conversion psi/MPa

psi	MPa	MPa	psi
1500	10.34	6.0	870.2
1600	11.03	6.5	942.7
1700	11.72	7.0	1015
1800	12.41	8.0	1160
1900	13.10	9.0	1305
2000	13.79	10.0	1450
2100	14.48	11.0	1595
2200	15.17	12.0	1740
2300	15.86	13.0	1885
2400	16.55	14.0	2031
2500	17.24	15.0	2176
2600	17.93	16.0	2321
2700	18.62	17.0	2466
2800	19.31	18.0	2611
2900	19.99	19.0	2756
3000	20.68	20.0	2901

Useful conversion factors Imperial to Metric (Approximate)

"SI" denotes the INTERNATIONAL SYSTEM of Metric Units adopted in Australia

THIS TABLE MAY BE USED IN TWO WAYS:				MULTIPLY COLUMN "A" BY COLUMN "B" TO OBTAIN COLUMN "C" ALTERNATIVELY DIVIDE COLUMN "C" BY COLUMN "B" TO OBTAIN COLUMN "A"			
REMARKS	A MULTIPLY	B BY	C TO OBTAIN	REMARKS	A MULTIPLY	B BY	C TO OBTAIN
AREA: Symbol m² The SI unit of AREA is the SQUARE METRE.	Square inches	645.16	mm ²	POWER: Symbol W The SI unit of POWER is the WATT.	Btu per hour (Btu/hr)	0.2931	W
	Square feet	0.929	m ²		horsepower (hp)	0.7457	kW
	Square yards	0.836	m ²		ton of refrigeration	3.517	kW
	Acre	4047	m ²				
	Hectare (ha)	10 000	m ²				
DENSITY: Symbol kg/m³ The SI unit of DENSITY is the kilogram per cubic metre.	lb/in ³	27.68	t/m ³	PRESSURE: Symbol Pa The SI unit of PRESSURE or stress is the NEWTON PER SQUARE METRE which has been given the name PASCAL. 1 N/m ² = 1 Pa = 0.000145lb/in ²	lb/ft ²	6.895	kPa
	lb/ft ³	16.02	kg/m ³		kip/in ² (1000 psi)	6.895	MPa
	lb/yd ³	0.5933	kg/m ³		lb/ft ²	47.88	Pa
ENERGY: Symbol J The SI unit of ENERGY is the JOULE. 1 J = 1 N.m A joule is the energy expended or the work done when a force of one newton moves the point of application a distance of one metre in the direction of that force.	1. ELECTRICAL ENERGY kilowatt hour (kW.h)		3.6	MJ	Vertical column (head) of water. (H ₂ O at 20°C) metres of water feet of water torr (vacuum) 1mm Hg. (mercury) 1in. Hg. (mercury) atmosphere (atm) microns	9.79	kPa
	2. HEAT ENERGY British thermal unit (Btu)		1.055	kJ		2.984	kPa
	Btu/gal	0.2321	kJ/L ††			0.1333	kPa
	Btu/ft ²	37.26	kJ/m ³			0.1333	kPa
3. MECHANICAL ENERGY <u>foot poundal</u> ft.pdl <u>inch pound-force</u> in.lbf <u>foot pound-force</u> ft.lbf <u>foot ton force</u> ft.tonf <u>Metre kilogram force</u> m.kgf		.04214	J	TORQUE: Symbol N.m (Moment of force) The SI unit of TORQUE is the NEWTON METRE. The newton metre is the work done when a force of one newton moves the point of application a distance of one metre in the direction of that force. 1 N.m = 1 J	<u>Poundal-foot</u> pdl.ft	.04214	N.m
		0.1130	J		<u>pound-force inch</u> lbf.inch	0.1130	N.m
		1.356	J		<u>lbf.inch</u> <u>pound-force feet</u>	1.152	kgf.cm
		3.037	kJ		<u>lbf.ft</u> <u>lbf.ft</u>	1.356	kgf.cm
		9.807	J		<u>ton-force feet</u> tonf.ft	13.83	kgf.cm
					<u>Metre kilogram force</u> m.kgf	3.037	kN.m
FORCE: Symbol N (NEWTON) The SI unit of FORCE (kg.m/s ²) has been given the special name – NEWTON. The newton is the force which when applied to a body having a mass of one kilogram, causes an acceleration of one metre per second in the direction of application of the force.	Poundal (pdl)	0.1383	N	VELOCITY: Symbol m/s The SI unit of VELOCITY is the METRE PER SECOND.	ft. per second (ft/s)	0.3048	m/s
	Pound-force (lbf)	4.448	N		ft. per minute (ft/min)	0.00508	m/s
	ton-force (tonf)	9.964	kN		miles per hour	0.4470	m/s
	*kilogram-force (kgf)	9.807	N		miles per hour	1.609	km/h
	*also known as kilopond (kp)						
FORCE PER UNIT LENGTH: Symbol N/m The SI unit of FORCE PER METRE: Symbol N/m	pounds-force per inch (lbf/in)	175.1	N/m	VOLUME: CAPACITY: Symbol m³ The SI unit of VOLUME is the CUBIC METRE.	DRY: cubic inch (in ³)	16387	mm ³
	pounds-force per foot (lbf/ft)	14.59	N/m		cubic foot (ft ³)	0.02832	m ³
	ton-force per foot (tonf/ft)	32.69	kN/m		cubic yard (yd ³)	0.7646	m ³
LENGTH: Symbol m The SI unit of LENGTH is the METRE.	inches	25.4	millimetres (mm)	NOTE: †† Capital "L" is now the legal preferred symbol for litre in Australia.	litre (L) ††	1 000 000	mm ³
	feet	0.3048	metres (m)		litre (L) ††	0.001	m ³
	yards	0.9144	metres (m)		gallons (Imp.)	0.004546	m ³
	chain	20.12	metres (m)				
	mile	1609	metres (m)		IMPERIAL LIQUID fluid ounce	28.41	millilitre (ml)
	mile	1.609	kilometres (km)		pint (20 fl. oz)	568.3	millilitre (ml)
MASS: Symbol kg The SI unit of MASS is the KILOGRAM.	ounce	28.35	grams (g)	VOLUME: RATE OF FLOW Symbol m³/s The SI unit of VOLUME RATE OF FLOW is the CUBIC METRE PER SECOND.	quart (2 pints)	1.137	litre (L) ††
	pound	0.4536	kilograms (kg)		gallon (Imp.)	4.546	litre (L) ††
	slug	14.59	kg		gallon (US)	3.785	litre (L) ††
	ton (2240 lb)	1016.05	kg		litre (water 4°C)	1.000	kilogram (kg)
	short ton (2000 lb)	907.2	kg		Imp. gallons (water 20°C)	4.536	kilograms (kg)
	ton (2240 lb)	1.016	tonne (t)				
	pounds per foot (lb/ft)	1.488	kg/m		Imp. gal. per minute (gal/min)	.000758	m ³ /s
	pounds per yard (lb/yd)	0.4961	kg/m		Imp. gal. per minute	0.272765	m ³ /hr
			Imp. gal. per minute	.0758	litre per second (L/s)		
			cubic ft. per minute	.000472	m ³ /s		
			cubic ft. per minute	0.472	litre per second (L/s) 1 m ³ = 1 kL		
			SUNDRY ITEMS:	miles per gallon	0.3540	km per litre	
				gallons per mile	2.825	litres per km	

TEMPERATURE

The SI unit of TEMPERATURE is the KELVIN - Symbol K. For most practical purposes of temperature measurement and most calculations involving temperatures, degrees Celsius, symbol °C will be used.

DEGREES FAHRENHEIT TO CELSIUS
(°F - 32) x 5/9 = °C

DEGREES CELSIUS TO FAHRENHEIT
(°C x 9/5) +32 = °F

Glossary of Terms

ABRASION RESISTANCE: Resistance to frictional rubbing, as distinct from resistant to knocks and impacts.

ANNEALING: A process involving heating and cooling, applied usually to induce softening. The term is also used to cover treatment to:-

- Remove stresses
- Alter mechanical or physical properties
- Produce a definite microstructure
- Remove dissolved glass

AUSTENITIC: The largest category of stainless steel, accounting for about 70 per cent of all production. The austenitic class offers the most resistance to corrosion in the stainless group, owing to its substantial nickel content and higher levels of chromium. Austenitic stainless steels are hardened and strengthened through cold working instead of heat treatment.

BEND TEST: A test of ductility where a test piece must withstand, without fracture, bending through a specific angle around a specified diameter.

CAMBER: The deviation of a side edge of metal sheet or strip from a straight line.

CHALKING: A chalk-line formation on the surface of an organic coating caused by the breakdown of the surface layer of resin, releasing pigment particles and fillers normally bound by the resin. This normally occurs after long-term exposure to sunlight.

COLD ROLLING: Is the reduction of hot-rolled pickled steel strip to a specified thickness, using a series of stands of rolls. This distorts the grain structure of the steel and also a loss of ductility.

COLD WORKING: Changing the structure and shape of steel by applying stress at low temperature.

DUCTILITY: The ability of a metal to deform from a flat condition into a complex shape without fracture.

ELASTICITY: That property of a material which causes it to resume its original form after removal of a load.

ELECTRIC RESISTANCE WELDED (ERW) PIPE: Pipe made from strips of hot-rolled steel which are passed through forming rolls and welded.

FINISH: Finish refers to the degree of smoothness or lustre of the sheet.

FLATNESS: The flatness of sheet metal may be defined as the absence of any waviness or buckle.

GALVANISING: The process of applying a coating of zinc to a surface of iron or steel to provide a corrosion resistant surface. Zinc coating may be applied by hot-dipping or electroplating.

GLOSS: The degree to which a painted surface possesses the property of reflecting light in a mirror like manner. COLORBOND® steel surfaces are produced in 10 per cent, 25 per cent and 80 per cent gloss.

HEAT TREATMENT: An operation or combination of operations involving the heating or cooling of a metal or alloy in a solid state for the purpose of obtaining desired conditions or properties.

KILLED STEEL: A steel with de-oxidants such as aluminium or silicon added before casting molten steel to remove oxygen and so prevent evolution of carbon monoxide and chemical segregation during cooling.

LOCK SEAMING: The closing of a tight seam of lock-formed edges of sheet metal. Snap lock-seam.

LUSTRE: Lustre finish is a smooth finish for electroplating achieved by using special prepared rolls. Some surface preparation by the plater may be necessary.

Glossary of Terms continued

MATT: Cold-rolled products are available with either a matt or lustre finish. The matt finish is produced by rolling with mechanically roughened rolls.

MECHANICAL PROPERTIES: Properties relating to the behaviour of materials under load in conventional mechanical tests. Such as elastic moduli, tensile strength, elongation, hardness.

NORMALISING: Heated steel to, and if necessary holding at, a suitable temperature above the transformation range, followed by cooling in a still atmosphere to ambient temperature in order to produce a medium-to fine pearlite microstructure.

PICKLING: Removal of oxide films from metal by immersion in an acid. The process is applied to scale removal from metal prior to operations such as cold rolling, wire drawing and electroplating. Absorption of hydrogen may occur in pickling causing embrittlement of hard steels and necessitating low temperature annealing for its removal.

PRESSING: Is a metal working process in which a flat blank, constrained between two surfaces, is forced by a punch to take a required shape.

PRIMER: The first coat of a painting system applied to an unpainted surface. It normally has very good adhesion and corrosion inhibitive properties.

ROLLING DIRECTION: The direction in which strip has been rolled. Longitudinal or Transverse.

SCALE: Layers of iron oxide formed on the surface of hot steel when oxygen in the air combines with iron from the steel.

SKIN-PASSING: A light cold rolling operation (about 1-2 per cent of cold works) which removes the yield point in steel which otherwise causes coil break, fluting or stretcher strain in subsequent operations.

SPANGLE: Grain or crystal of zinc, or zinc/aluminium as appearing on hot-dipped metallic coated steel.

STRESS RELIEVING: Heating a metal to, and holding it at, some temperature generally below recrystallisation range, followed by uniform cooling, for the purpose of removing internal stresses.

STRETCHER LEVELLED: As applied to sheets, indicates a standard of flatness. Originating from an early method of gripping the ends of sheet and stretching it to remove buckles.

STRIP: A continuously rolled flat product of any width and thickness, supplied rolled up into a coil form.

TEMPER: To modify hardness of metals. Adjustment of hardness of heat treated article by controlled heating after quenching. Increase of hardness by cold rolling. The degree of cold rolling is variable depending on the required hardness and is more than that of skin-passing.

TENSILE TEST: A standard sample of material is placed between two jaws and drawn apart in a tensile testing machine until fracture. The ultimate tensile strength is the load divided by the cross section area of the sample.

WASH COAT: The coating applied to the back or exposed side of the painted strip.

YIELD POINT / YIELD STRENGTH: Defined in engineering and materials science as the stress at which a material begins to deform plastically. Prior to yield point, the material will deform elastically and will return to its original shape when the applied stress is removed. Once the yield point is passed some fraction of the deformation will be permanent and non-reversible.

Important Details

My local OneSteel Steel & Tube outlet details

Ph: _____ Fax: _____ Email: _____

My local OneSteel Steel & Tube Account representatives

Sales

Ph: _____ Fax: _____ Email: _____

Credit

Ph: _____ Fax: _____ Email: _____

My OneSteel Steel & Tube Account Number

A/c N: _____

My Industry Memberships

Safety Reminder

SAFETY AT WORK

OneSteel believes that a strong focus on safety in all workplaces is essential.

“The most important reason for making your workplace safe, is not at work at all.”¹

The most treasured moments of our lives happen outside of work, which is why it is so important to go home safely. An incident at work affects more than just the injured person. OneSteel encourages you to take a moment before commencing any task to consider your safety and the safety of others.

SAFETY AT OUR SITES

OneSteel does not compromise on safety, and we believe that all injuries, occupational illnesses and incidents are preventable. Achieving zero incidents is possible in all OneSteel businesses by maintaining a strong focus on the health and safety of all employees, contractors and customers. OneSteel’s “Goal Zero” target aims to ensure employees can go home in the same condition that they came to work.

OneSteel has implemented stringent safety policies and procedures that enable us to strive for our safety goal. **We appreciate your compliance with our safety policies when you visit our sites.**

1. Safety message reproduced from QLD Government’s Workplace Health & Safety Initiative 2008 “Homecomings”.





STEP UP, WITH STEEL

COST SAVINGS AND REDUCED CONSTRUCTION TIME - TWO OF THE REASONS WHY STEEL USE HAS RISEN SUBSTANTIALLY

OneSteel offers several services **free of charge** to assist building owners, developers, builders, architects, engineers and fabricators with the development of economical steel framing solutions for multi-storey building projects. These services include:

Preliminary Steel Design

Our design team has been successfully used by major builders and engineers to assist with the conceptual design of medium and high rise steel framed buildings throughout Australia. This service assists with the preliminary design phase. Full design & documentation is still undertaken by the respective Consulting Engineer appointed to the project.

Advice on Fire Protection Requirements for Structural Steelwork

Using OneSteel's fire engineers at CESARE, Victoria University, we are able to provide a review of the deemed-to-satisfy requirements for fire protection of the building frame as well as advice on an alternative solution as allowed under the Building Code of Australia that may reduce or eliminate the need for passive fire protection on some or all elements of the steel frame. The purpose of this advice would be to provide assistance to the project Fire Engineer in the preparation of their Fire Engineering Assessment Report.

For more information regarding these and other services, contact your local OneSteel Steel & Tube representative, who will discuss your project with OneSteel Manufacturing's Business Development Managers.

onesteel

...find this guide useful? see what else we can offer you!



Product & Services Brochures

Find out about who OneSteel Steel & Tube are and what we can do for you with our Business Overview and our National Processing Solutions brochures.



Connect: OneSteel Steel & Tube's Customer Newsletter.

Our bi-annual customer newsletter gives you a unique insight into the types of businesses we partner nationally and the initiatives that are occurring within our network of OneSteel Steel & Tube sites.



Quarterly Market Updates

Want to keep up to date with information about the Australian steel market and the global steel industry? We can email you our quarterly Market Updates, so you can continue to be informed.



Get invited to Customer Events and receive News and Service Information

We like to regularly update all of our customers with new product information and invitations to upcoming customer and industry events. So if you don't want to be the last person to find out, sign up to receive our Customer Events, News and Service information today.

As a leader in national steel distribution, OneSteel Steel & Tube offer a comprehensive range of steel products, processing solutions and project management expertise, whatever your industry.

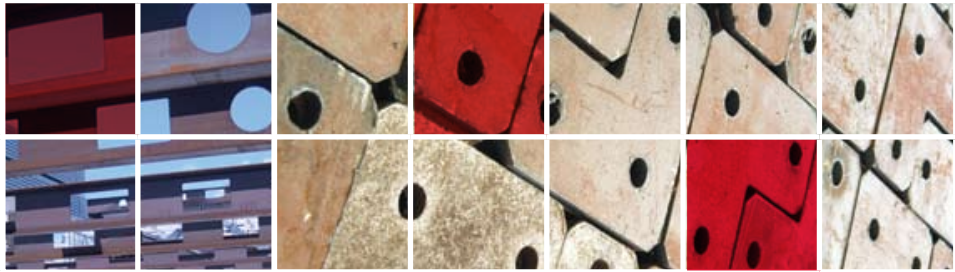
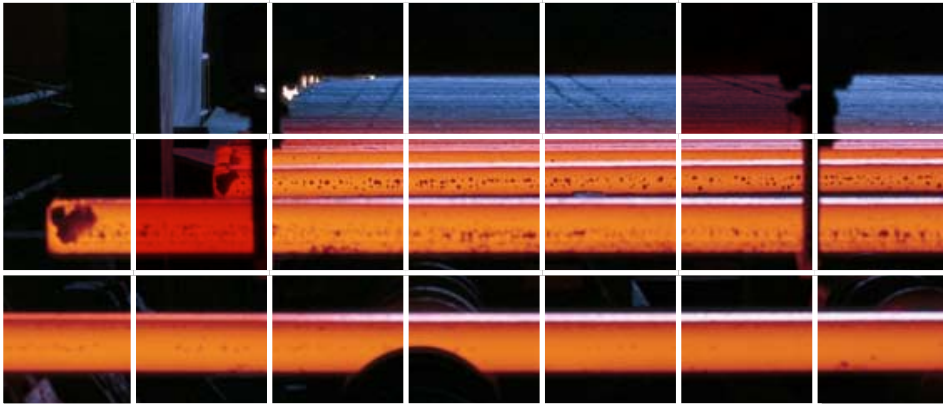

onesteel.com/steelandtube

steel&tube@onesteel.com

onesteel
steel & tube